

Operating instructions

Air Entrainment Meter 8 litre, Type 7302
with Hand-Operated Pump

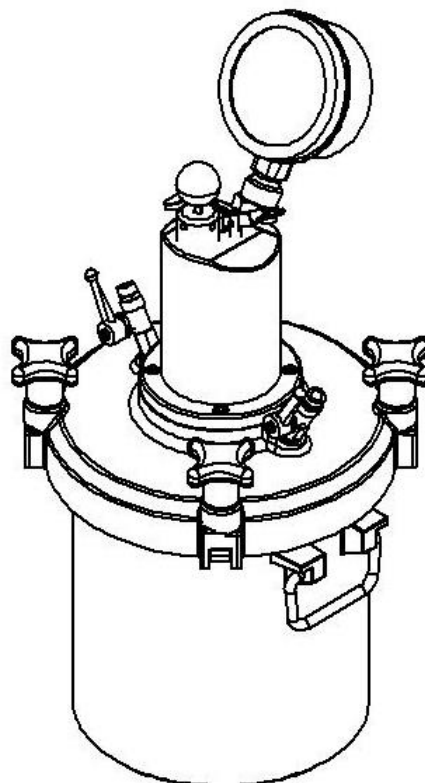

Importance of this Operational Manual:

Warning: It is expected that users and operators read and understand this entire Operational Manual before putting the system into operation. Reading and understanding the entire Operational Manual are absolutely necessary before operating the system.

Contents

Page no.:

1. Basic instructions	3
1.1 Purpose for which this system was designed	3
1.2 Purposes for which this system may NOT be used	4
1.3 Safety instructions	4
1.3.1 Obligations of the User and Operator	4
1.3.2 Safety elements	4
1.4 Receiving the system from the forwarding agent; transport.....	5
1.4.1 Receiving the system from the forwarding agent	5
1.4.2 Transport of the equipment	5
1.5 Equipment delivered with this system.....	6
1.6 Technical data	6
1.6.1 Operation of the system.....	6
1.6.2 Basic elements and characteristics of the Air Entrainment Meter	6
2. The testing procedure	7
3. Cleaning and maintenance	8
4. Checking and calibrating the Air Entrainment Meter	9
4.1 Determining the initial pressure	9
4.2 Calibration	10
5. Troubleshooting	12
6. After-sales service and spare parts	13
6.1 Date of issue of this Operational Manual.....	13
6.2 Copyright	13
6.3 Contact for help and spare parts	13

Attachments:

- Spare parts
- Exploded-view drawing showing the constructional configuration and the functional elements of the Air Entrainment Meter: 8 litre
- Drawing: “Sequence of Steps” for testing the device

1. Basic instructions

1.1 Purpose for which this system was designed

This Operational Manual contains the information required for operation of the product described here, for the purpose for which they have been designed. This Operational Manual is intended to be used only by technically qualified staff.

“Technically qualified staff” is defined as those persons who – as a result of their training; their experience; the instructions which they have received; as well as their knowledge of the relevant standards, regulations, accident-prevention regulations, and conditions under which the product will be operated in the company – have been authorized by the person responsible for the safety of the company facilities and staff to carry out the activities and actions required for operation of the equipment described below, and who can recognize and prevent any possible dangers arising from such operation (this definition of technically qualified staff has been provided in IEC 364).

The User must by all means observe the requirements and limit values, as well as all safety instructions, given in this Operational Manual. Any use of this device not in conformity with these stipulations shall be considered to be in violation of the use for which this system was intended. If this device must be operated under special conditions, or with special modes of operation, then this is authorized only after consultation with the manufacturer, and after obtaining his prior and express approval.

This 8-litre Air Entrainment Meter, Type 2.7302 (manual version), has been designed and constructed in accordance with the following standards: DIN 1048, ASTM C 231 und BS 1881.

To improve the workability of the concrete mixture, and to enhance the durability of concrete under conditions of frost and thawing weather conditions, admixtures are mixed in with the concrete during its preparation that promote the development of air voids. If properly applied, this technique can achieve an optimum in the feasible technological enhancement of the mixture of air and concrete in the total concrete volume. Frequent tests are essential in order to maintain at a constant level the air entrainment level that has been determined as optimal for a particular kind of concrete. This Air Entrainment Meter monitors the effects of air-entraining admixtures for the specified concrete mixtures.

The purpose of the 8-litre Air Entrainment Meter, Type 2.7302 (manual version), is to measure the air entrainment (air-void content) of fresh concret. The pressure gauge gives a direct reading of the air content in per cent (%).

1.2 Purposes for which this system may NOT be used

- This 8-litre Air Entrainment Meter, Type 2.7302 (manual version), may NOT be used for any other construction materials than those stated above in Section 1.1.
- This system may not be used before all the inner surfaces of the test pot and the cover of this pot have been cleaned of oils, fats, dust, and residue from earlier testing. Only then may the new material to be tested be placed in the test pot.

1.3 Safety instructions

1.3.1 Obligations of the User and Operator

This 8-litre Air Entrainment Meter, Type 2.7302 (manual version), has been designed and built in accordance with the state of the engineering art and with the accepted rules of good engineering practice. The use of this Air Entrainment Meter, however, can cause danger to the health and safety of the User and third parties. It can also cause damage to mechanical parts or to other objects of value.

The person operating this system must take care that he or she does not endanger the health and safety of himself/herself, or of any other persons. No person may operate this system without supervision unless he or she has received sufficient instruction in its operation.

This 8-litre Air Entrainment Meter, Type 2.7302 (manual version), may be used only:

- For the purpose for which it was intended
- In a technical condition in which it can be perfectly safely operated.

If the 8-litre Air Entrainment Meter, Type 2.7302 (manual version), is damaged, or has any malfunctions which can impair its operational safety, these malfunctions must be immediately eliminated. This system may not be further operated until all such malfunctions or shortcomings have been eliminated.

1.3.2 Safety elements

Safety lock for securing the hand pump during transport

The pump piston must be screwed down tight before transporting the 8-litre Air Entrainment Meter, in order to prevent damage during transport. To lock the hand pump, screw the ball head (the knob) with the thread, tight against the upper part (cap) of the unit.

1.4 Receiving the system from the forwarding agent; transport

1.4.1 Receiving the system from the forwarding agent

When the system arrives from the forwarding agent, make an external inspection. If there are no visible damages or other shortcomings, accept the consignment from the freight forwarder (the package service or a haulage agent).

If there are no transport damages or other shortcomings, use the bill of delivery to check to make sure that the delivery is complete.

If you believe that transport damage may have taken place when you receive the equipment, or if you discover after you have accepted the delivery that damage has occurred, immediately make a report of this damage, with an exact description of the nature and the extent of the damage. Send this report to us immediately by fax. Important: Be sure not to make any changes or other alterations to the system as it has been delivered.

When we receive this report, we shall decide whether we can solve the difficulty by one of the following steps:

- Delivery to you of spare parts
- Sending a specialist fitter or mechanic to your company
- Asking for return of the system to us for replacement or repair.

1.4.2 Transport of the equipment

The equipment is delivered in especially designed cardboard boxes. The open spaces inside the boxes are filled with cushioning material to prevent damage during transport.

After the 8-litre Air Entrainment Meter, Type 2.7302 (manual version), has been unpacked from the transport box, it can be lifted out of the box by hand and moved by hand to the place where it is to be used.

At all times, allow the Air Entrainment Meter to rest in an upright (standing) position. The pressure gauge of the Air Entrainment Meter is a sensitive device; as a result, do not subject the unit to knocks, bumps, vibrations, or impacts while it is being moved about. Before transporting the Air Entrainment Meter, be sure to use the ball handle (knob) to screw down the pump piston tight.

The weight (mass) of the Air Entrainment Meter is approx. 9,5kg.

1.5 Equipment delivered with this system

The standard equipment delivered with this Air Entrainment Meter includes the following:

- Air Entrainment Meter
- Calibration set.

Optional equipment delivered at extra cost:

- 1 ea. attachment ring for filling the meter
- 1 ea. transport container
- 1 ea. tamper and straightedge for striking off the test concrete

On request you receive a calibrating certificate of us which you can use for the test resources supervision as a proof in the context of your quality management system for your Air Entrainment Meter for an extra charge.

1.6 Technical data

1.6.1 Operation of the system

The 8-litre Air Entrainment Meter, Type 2.7302 (manual version), operates on the principle of Boyle-Mariott's law. The system measures the air content of the concrete in accordance with a pressure-compensation process. The Air Entrainment Meter has a pressure chamber in which a specified air pressure is produced by a hand pump. When an overflow valve is opened, pressure equalization is established with respect to the test pot, which is filled with concrete. The pressure drop is a measure of the air content in the concrete.

Basic operating instructions:

When using the pump piston, be sure to follow the instructions below:

Pump piston rod	Loose:	For conduct of testing
	Screwed down tight:	For transport and cleaning

1.6.2 Basic elements and characteristics of the Air Entrainment Meter

This Air Entrainment Meter is made of cast aluminium. The test pot is connected air-tight to the upper part of the Air Entrainment Meter by means of locking bolts with star-handle palm grips. Two ball shut-off valves are provided to fill in the water and to release the air.

A hand pump integrated into the system provides the compressed air. A correction valve for the initial pressure, and the overflow valve, are both integrated into the pressure chamber. The correction valve is a sensitive needle valve with a knurled thumb screw.

The overflow valve serves for pressure equalization between the pressure chamber and the test pot. This valve is opened by means of a rocker lever. The pressure gauge is installed directly on the pressure chamber. The scale provides readings from 0 to 100%.

Technical data:	
Filling capacity:	8 litre
Filling material (test specimen):	Fresh concrete
Reading from display:	A pressure gauge, with readings in per cent
Exactness class of pressure gauge:	Class 1.0
Dimensions:	ø200x650mm
Weight (mass):	9,5 kg

2. The testing procedure

Important:	Be sure to clean the entire inner surfaces of the test compartment (the pot and the cover to the pot) so that there is no oil, grease, fat, dust, or residue from a previous testing procedure in the compartment where the new test specimen is to be placed. Make sure that the cover to the test compartment is also thoroughly clean.
-------------------	---

1. Take off the cap of the Air Entrainment Meter. This is the upper part with the pressure-gauge mounting. Set in place the attachment ring for filling the meter (this is an optional piece of equipment: you may not have received this part).
2. Fill the test pot with fresh concrete and compact the concrete by using a tamping rod, or by using a vibrating table.
3. Take off the attachment ring for filling the meter (if you have used it).
4. Strike off the concrete smooth with the top of the pot by using the straightedge for striking off (this is an optional piece of equipment: you may not have received this part).
5. Place the upper part of the Air Entrainment Meter onto the lower part, and turn it 90° to lock it into place.
6. Press the rocker lever to allow the air to flow from the pressure chamber into the test pot.
7. Open the two ball shut-off valves. They are open when their levers are pointing upward.
8. Use a squeeze bottle to fill water into the left ball shut-off valve until all the air has escaped from the Air Entrainment Meter through the right ball shut-off valve. To make sure all air has escaped from the device, tilt the Air Entrainment Meter to the left until the right ball shut-off valve is pointing vertically. See Fig. 3 of the drawing "Sequence of Steps" at the end of these instructions. **Important:** it is absolutely necessary that you let the water flow out of the right ball shut-off valve **until it no longer contains bubbles**.
9. Now close both of the shut-off valves.
10. Turn the ball-headed knob to the left to release (unlock) the pump piston rod of the hand pump. Now pump up the Air Entrainment Meter until the black pointer of the pressure gauge is exactly over the red marking pointer. This is the initial pressure. If you have allowed the black pointer to go too far (i.e., past the red marking pointer),

correct the pressure by briefly pressing the correction valve. Tap with your finger gently against the dial of the pressure gauge until the pointer comes to rest.

Note:	After you have pumped up the Air Entrainment Meter, do NOT screw in the ball knob of the pump piston to the right. Screwing it in to the right is necessary only for transport safety, or to lock the piston in place while the Air Entrainment Meter is being cleaned (so that no water can enter into the pump sleeve).
--------------	---

11. Press the rocker lever to allow the air to flow from the pressure chamber into the test pot. Hold down the rocker lever until pressure equalization has been reached. Tap gently with your finger against the dial of the pressure gauge, until the pointer comes to rest.
12. Read off the air content of the fresh concrete in per cent.
13. After the testing is finished, slowly open both of the two ball shut-off valves. This will allow the pressure to be released from the test pot.
14. Open the overflow valve by pressing the rocker lever. This will allow the remaining air to escape from the pressure chamber into the test pot. The pointer of the pressure gauge will now slowly fall back to its starting position.

Warning!	It is absolutely necessary to perform the steps of work in the exact order as listed here. Do not operate the thumb lever if there is still pressure in the 1-litre pot and if there is already reduced pressure in the pressure chamber. This would cause the air pressure to force water out of the test pot into the pressure chamber. This would in turn cause a change in the volume of the air content of the pressure chamber. The result would be incorrect measurements.
-----------------	--

3. Cleaning and maintenance

If the 8-litre Air Entrainment Meter, Type 2.7302 (manual version), is properly used, it needs no special maintenance.

After performing a test, carefully clean the Air Entrainment Meter with a moist sponge, and dry it off. Rinse the ball shut-off valves thoroughly with water. After testing, use special oil to coat the parts of the Air Entrainment Meter that are not coated with paint:

The lower surface of the upper part (cap) of the Air Entrainment Meter, The inside surfaces of the test pot, The ball shut-off valves. Use this special oil in the same way in which you oil three-gang moulds for concrete cube testing. This special oil must be ordered from TESTING.

Warning:	Never immerse the Air Entrainment Meter in water. It is not a submarine. The machine is protected against spray water, but it is not waterproof.
	When cleaning the Air Entrainment Meter, be sure to lock the pump piston rod by screwing it tightly to the right. This will prevent water from entering the Air Entrainment Meter through the pump.

4. Checking and calibrating the Air Entrainment Meter

4.1 Determining the initial pressure

The initial pressure is the pressure to which you have pumped up the Air Entrainment Meter before you begin testing. On the pressure-gauge scale, this pressure is at the left of the zero point, and is marked by a red marking pointer. This additional air volume will compensate for the loss of air volume during testing of the air content (this loss of air volume is due to the technical design of the device). The correct initial pressure has already been marked during factory testing, before each Air Entrainment Meter is shipped to its users.

The initial pressure may require re-setting, however. To do this, first remove the threaded ring and the transparent plexiglas cover of the pressure gauge. Then make a provisional pre-setting by placing the red marking pointer at some point to the left of the zero position. Now, to set the red marking pointer to its correct position for testing, follow the steps below:

1. Remove the upper part (cap) of the Air Entrainment Meter. Take the thick hose and insert it from below into the hole that has been drilled for the left ball shut-off valve.
2. Fill the test pot with water, up to the top.
3. Place the upper part (cap) of the Air Entrainment Meter back into its normal position.
4. Press the rocker lever to allow the air to flow from the pressure chamber into the test pot.
5. Open the two ball shut-off valves. They are open when their levers are pointing upward.
6. Use a squeeze bottle to fill water into the left ball shut-off valve until all the air has escaped from the Air Entrainment Meter through the right ball shut-off valve. To make sure all air has escaped from the device, tilt the Air Entrainment Meter to the left until the right ball shut-off valve is pointing vertically. See Fig. 3 of the drawing "Sequence of Steps" at the end of these instructions. Important: it is absolutely necessary that you let the water flow out of the right ball shut-off valve until it no longer contains bubbles.
7. Now close both of the shut-off valves.
8. Turn the ball-headed knob to the left to release (unlock) the pump piston rod of the hand pump. Now pump up the Air Entrainment Meter until the black pointer of the pressure gauge is exactly over the red marking pointer. This is the initial pressure. If the pointer goes past the red marking pointer, then correct the pressure by using the knurled thumb screw on the correction valve. Tap with your finger gently against the dial of the pressure gauge until the pointer comes to rest.
9. Open the overflow valve by pressing the rocker lever. This will allow the remaining air to escape from the pressure chamber into the test pot. The pointer of the pressure gauge will now slowly fall back to its starting position.

Three results are now possible:

- I. If the black pointer goes to zero, the position of the red marking pointer is correct. If this is the result, skip the instructions below and continue with Section 4.2 below.

- II. If the pressure-gauge pointer goes past the zero point (for example, if it goes to 0.1% or 0.2%), you must push the red marking pointer farther to the left. To do this, it is necessary to remove the threaded ring and the transparent plexiglas cover of the pressure gauge.
- III. If the pressure-gauge pointer does not reach the zero point, then push the red marking pointer in the direction of zero. To do this, it is necessary to remove the threaded ring and the transparent plexiglas cover of the pressure gauge.

- ⇒ Carefully open the right ball shut-off valve, to release the pressure from the test pot.
- ⇒ Now go back to step 5 above, and repeat steps 5 to 9.

If the pressure-gauge pointer now goes to zero, then the setting of the red marking pointer is correct.

If the pressure-gauge pointer does not reach zero, then the red marking pointer must be re-set again as required. You will then have to repeat the steps as described above.

If the pointer does not come to rest, the Air Entrainment Meter is not air-tight.

4.2 Calibration

From time to time it is necessary to check the readings to make sure they are accurate. A calibration set has been delivered with the Air Entrainment Meter to check the accuracy of the readings.

Actually, we calibrate all new or repaired Air Entrainment Meters at our factory, as a general policy. You can, however, calibrate the Air Entrainment Meter yourself.

To calibrate the Air Entrainment Meter, you will need to take 400ml of water from the unit (= 400cm³). This amounts to 5% of the content of the test pot (8litre = 8000cm³).

You have determined the correct initial pressure as described under Section 4.1 above.

The pressure-gauge pointer is now pointing to zero. Now, after you have successfully completed steps 1 to 9 as described above, carry out the following steps:

10. Take the hose with 4-mm diameter and screw it onto the left ball shut-off valve.
11. Hold the free end of this hose over the top of a graduated cylinder (this graduated cylinder must have a volume of at least 400ml).
12. Carefully and slowly open the left ball shut-off valve and allow water to flow from the Air Entrainment Meter into the graduated cylinder. Now activate the overflow valve by pressing the rocker lever. After exactly 100ml of water has flowed into the graduated cylinder, close the ball shut-off valve.
13. It may happen that the water stops flowing before 400ml has flowed out into the graduated cylinder. In such a case, close the left ball shut-off valve when the water stops flowing. Then pump up the pressure chamber so that there is enough pressure in the chamber to start the water flow again. Pump up the pressure chamber until the pressure-gauge pointer reaches the red marking. Then activate the overflow valve by pressing the rocker lever, and once again open the left ball shut-off valve until the water again flows into the graduated cylinder. Repeat the above procedure until the required amount of 400ml of water has flowed into the graduated cylinder.

14. Slowly and carefully open the right ball shut-off valve to release the pressure from the test pot.
15. Now close both of the ball shut-off valves.
16. Use the hand pump to pump up the Air Entrainment Meter, until the black pressure-gauge pointer stands exactly over the red marking pointer (initial pressure). If you have allowed the black pointer to go too far (i.e., past the red marking pointer), correct the pressure by briefly pressing the correction valve. Tap with your finger gently against the dial of the pressure gauge until the pointer comes to rest.
17. Press the rocker lever to activate the overflow valve. This will allow the air from the pressure chamber to flow into the test pot. Hold down the TEST button until pressure equalization has been reached. Tap gently with your finger against the dial of the pressure gauge, until the pointer comes to rest.

Check the accuracy of the reading on the gauge. You have removed 5% of the volume from the test pot: 400ml. **As a result, the reading on the pressure gauge should now also read 5%, if this reading is correct.**

If the reading is not 5%, get in contact with the manufacturer. You may have to send the complete Air Entrainment Meter back to the manufacturer for him to check the system.

18. After you have made the reading, slowly open the right ball shut-off valve, to release the pressure from the test pot.
19. Open the overflow valve by pressing the rocker lever, to allow the remaining air to flow from the pressure chamber into the test pot. During this step, the pressure-gauge pointer will slowly fall and will return to its initial position.
20. Remove the calibration hoses. Empty the test pot. Wipe the Air Entrainment Meter dry and oil the parts as described above.

Your 8-litre Air Entrainment Meter, Type 2.7302 (manual version), is now ready for operation.

5. Troubleshooting

Fault	Possible cause	Action to take
The Air Entrainment Meter repeatedly shows incorrect measuring results	The Air Entrainment Meter has a leak.	Please get in touch with the manufacturer.
	The pump piston rod is bent (which changes the volume in the pressure chamber)	Get in touch with the manufacturer: the Air Entrainment Meter must be completely repaired.
	The ball shut-off valves are open.	Close the ball shut-off valves.
	The fast-action clamps do not close properly.	Adjust the fast-action clamps. Re-calibrate the Air Entrainment Meter.
	Pointer is not in correct position.	Correct the position of the pointer. See Section 4.1.

6. After-sales service and spare parts

A great deal of care has been taken to ensure that this Operational Manual is correct. We cannot, however, guarantee that it is without mistakes or errors, or that all information contained herein will continue to remain valid in the event of technical changes.

6.1 Date of issue of this Operational Manual

Edition no. 8
Date of issue: Jan of 2009

6.2 Copyright

The copyright to this Operational Manual remains with the company

TESTING Bluhm & Feuerherdt GmbH.

This Operational Manual is intended only for the Operator, the User, and his staff. The information in this Operational Manual may not be:

- Reproduced, or
- Distributed, or
- Provided to any other persons.

Any person acting in violation of the above stipulations may be prosecuted before a court of law.

6.3 Contact for help and spare parts

If you have any technical questions, or if you require spare parts, please get directly in touch with the following address:

TESTING Bluhm & Feuerherdt GmbH
Motzener Str. 26b
DE – 12277 Berlin
Germany
Tel. +49 / 30 / 710 96 45-0
Fax: +49 / 30 / 710 96 45-98
E-mail: info@testing.de
www.testing.de

Air Entrainment Meter
8 Litre
2.7302



Spare parts

8-litre Air Entrainment Meter, Type 2.7302 (manual version)

article no. old	article no. new	amount	name	incl. pieces
2.7302	2.7302	1	air entrainment meter	
	2.7302-O	1	upper part without test pot	
2.7302-01	2.7302-A1	1	test pot complete	
2.7302-02.01	2.7302-A2-01	1	cover unit with o-ring	
N-LP-103	OR-204.2x5.6	1	O-ring \varnothing 123x6,2 for cover unit	
N-LP-40	Pn-001L	1	left shut-off valve	cu-sealing (2x0,3/2x0,5)
N-LP-41	Pn-001R	1	right shut-off valve	cu-sealing (2x0,3/2x0,5)
2.7302-05	LP-B-02	4	locking bolt complete	star knob, washer a. bolt
N-LP06	LP-B-03	1	rocker arm	retaining rings, bolt
2.7302-04	2.7302-A4	1	needle valve complete	o-ring, bolt, spring etc.
N-LP07	LP-B-04	1	correction valve	
N-LP08	LP-B-05	1	double fitting complete	o-rings, pipe socket
2.7302-07	2.7302-A5	1	hand pump complete	
2.7302-07-1b	2.7302-A5-01	1	pump jacket complete	
N-LP03	LP-B-01	1	bottom valve	
2.7302-11	2.7302-A5-02	1	pump rod complete	
2.7302-08	2.7302-A6	1	pressure gauge complete	
2.7302-09	2.7302-DS	1	sealing set complete	
N-LP-23	LP-PM-01	1	sealing for pump	
	2.0334-MS	1	manometer spare part set	threaded ring, disk, o-ring

Air Entrainment Meter
8 Litre
2.7302

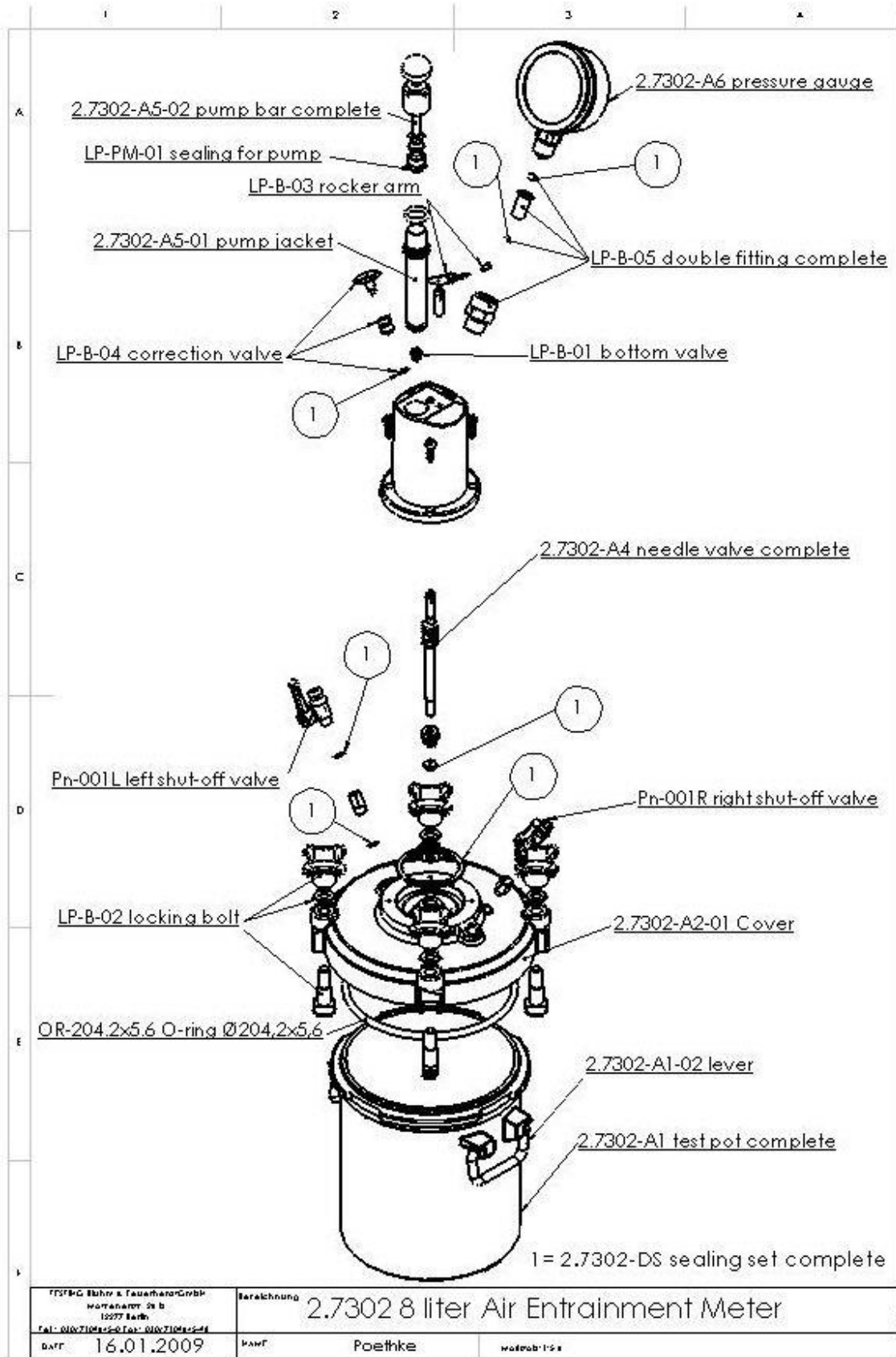

Drucktopf mit frischem Beton füllen, der durch Rütteln oder Stampfen eingebracht wird (wie Beton auf der Baustelle). Das übervolle Gefäß mit dem mitgelieferten Abstreichlineal glattstreichen. Den oberen Rand sauberwischen.

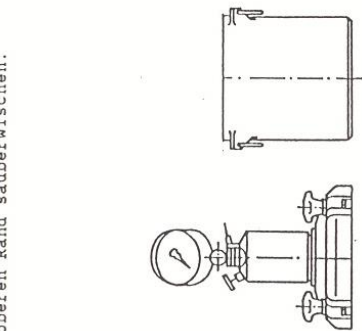

Den Topf waagrecht ausrichten und den Deckel aufsetzen. Die Hähne bleiben dabei offen.

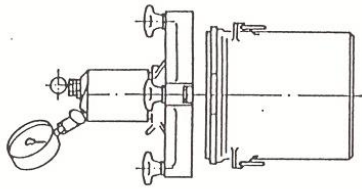

Wasser in den einen Hahn einfüllen, bis alle Luft durch den gegenüberliegenden Hahn entwichen ist. Beide Hähne bleiben offen.

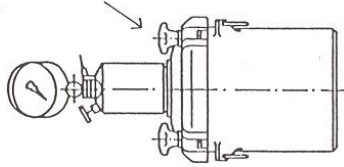

Durch Linksrehen des Knopfes die Pumpenstange der eingebauten Luftpumpe lösen und Luft einpumpen, bis der Zeiger auf der Marke "Anfangsdruck" steht.

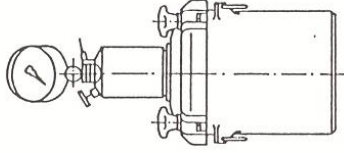

Den prozentualen Luftgehalt des Betons an der Skala ablesen.

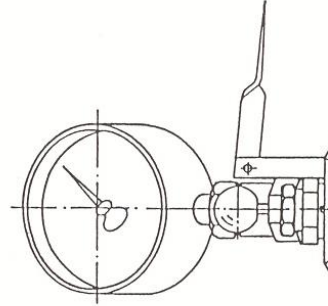

Zur Kontrolle der Genauigkeit des Luftgehaltsprüfers Prüfschlauch und Meßzylinder verwenden.

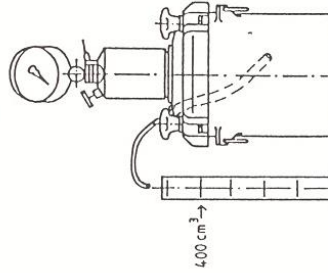

Einige Sekunden warten und Zeigerstellung korrigieren (Nachpumpen oder Luftblassen aus dem Nadelventil). Beide Hähne schließen und Daumenhebel herunterdrücken, um die Luft in das Gefäß einzulassen. Den Daumenhebel einige Sekunden heruntergedrückt halten und mit dem Finger leicht an das Zifferblatt klopfen, bis der Zeiger zur Ruhe kommt.

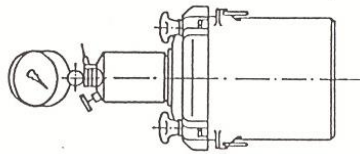

1991		Datum		Name	
Bearb.	19.9.91	Prüfzeit			
Gepr.					
Norm.					
Zust.	Änderung	Datum	Name		
Auflrag					
Luftporengehaltsprüfer				Beitf. 2	
Bedienungsanleitung				7300	
BLUHM+FEUERHERDT				Cr. d.	
Baustoff-Prüfgeräte				D 1000 Berlin	