

# Operating Manual

## Climate-Controlled Chest for Concrete Test Specimens

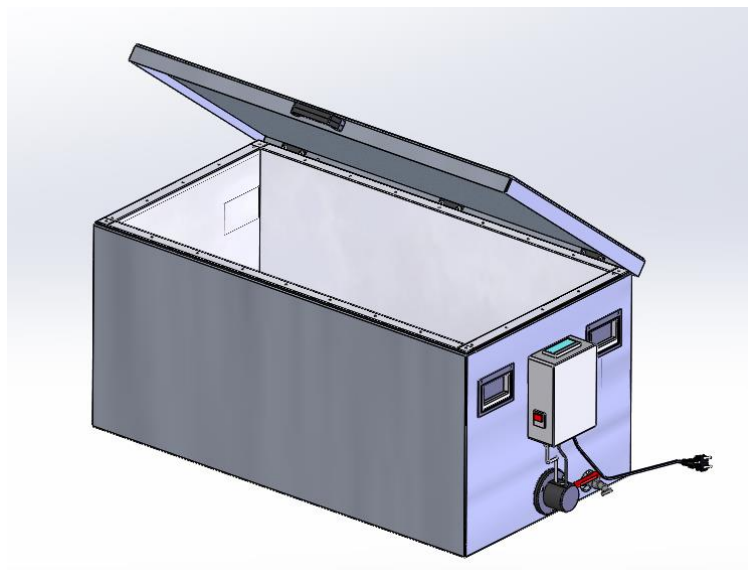

**IMPORTANT:**

Do not place this device into operation before you have become familiar with the function and the position of all its control systems.

<b>Contents</b>	<b>Page</b>
<b>1. Basic instructions</b> .....	<b>3</b>
1.1 Designation .....	3
1.2 Purpose for which this system was designed .....	3
1.3 Improper use .....	4
1.4 Guarantee .....	4
1.5 Acceptance of delivery, transport .....	5
1.5.1 Acceptance of delivery .....	5
1.5.2 Transport .....	5
1.6 Scope of delivery .....	6
1.7 Connection to the power supply .....	6
<b>2 Basic safety instructions</b> .....	<b>7</b>
2.1 Obligations of the operator / user .....	7
2.2 Danger in work with the Climate-Controlled Chest .....	7
2.3 Regular checks.....	7
2.4 Information about the CE symbol .....	7
<b>3. Technical data</b> .....	<b>8</b>
3.1 Description of the Climate-Controlled Chest.....	8
3.2 Electrical features .....	8
2.3 Technical data .....	8
<b>4. Placing the Climate-Controlled Chest into operation.....</b>	<b>9</b>
4.1 General recurring operating steps .....	9
4.2 Description of the temperature controller.....	10
4.3 Displays.....	10
4.4 Messages and warnings on the display.....	11
4.5 Setting the control parameters (P level) .....	12
<b>5. Maintenance and emptying</b> .....	<b>13</b>
<b>6. Troubleshooting</b> .....	<b>13</b>
<b>7. After-sales service</b> .....	<b>14</b>
7.1 Date of this version of the Operating Manual .....	14
7.2 Copyright .....	14
7.3 Spare parts and technical help .....	14

Attachments:  
European Union Declaration of Conformity  
circuit diagram  
Testing and Measuring Record

## 1. Basic instructions

### 1.1 Designation

Designation of the device: Please see the name plate on the Climate-Controlled Chest, which shows the complete characteristic data and the electric properties of the system.

### 1.2 Purpose for which this system was designed

This Operating Manual contains the information required for operation of the products described here, for the purpose for which they have been designed. This Operating Manual is intended to be used only by technically qualified staff.

“Technically qualified staff” is defined as those persons who – as a result of their training; their experience; the instructions which they have received; as well as their knowledge of the relevant standards, regulations, accident-prevention regulations, and conditions of product operation in the company – have been authorized by the person responsible for the safety of the company equipment to carry out the activities and actions required for operation of the equipment described below, and who can recognize and prevent any possible dangers arising from such operation (this definition of technically qualified staff has been provided in IEC 364).

This Climate-Controlled Chest is designed only for water storage of concrete test specimens at a prescribed test temperature. This system is intended for operation in dry rooms.

#### *Recommended storage configuration of concrete specimens*

18 pce of concrete test cubes: 150 x 150 x 150



The max. The load capacity of the air-conditioning system is 300 kg

(other specimen geometry and dimensions are also possible).

Do not fill the water past the marked limit level. The maximum level is approx. 4 cm under the top edge of the water tank of the Climate-Controlled Chest.

The User must by all means observe the requirements and limit values, as well as all safety instructions, given in this Operating Manual. Any use of this device not in conformity with these stipulations shall be considered to be in violation of the use for which this system was intended. If this device must be operated under special conditions, or with special modes of operation, then this shall be authorized only after consultation with the manufacturer, and after obtaining his prior and express approval.

This operating manual contains safety instructions that are to be observed in order to exclude any risk of fatalities, injuries, damage to the equipment or improper operation. Safety markings are as follows:

<p>Caution!</p> 	<p>This warning refers to dangers that could cause material damage.</p>
<p>Danger</p> 	<p>This warning refers to dangers that could cause severe injuries or even fatalities.</p>
<p>Note</p> 	<p>Provides practical advice on operation</p>

### 1.3 Improper use

The Climate-Controlled Chest is not designed for operation under the following conditions, and may therefore not be used in such cases:

- The operation **without water**.
- The Climate-Controlled Chest must not be used on a surface that is not level and on a surface that cannot safely support its weight.
- may not be operated with explosive liquids
- may not be filled or operated with materials that have a low melting temperature.
- may not be used under dangerous, adverse, or any other unfavourable conditions.

If the user heats the water to a temperature higher than the default required temperature set at the manufacturer's plant (20 °C), this can produce place an additional load on the Climate-Controlled Chest and can shorten the service life of the tubular heating element.

<p>Caution!</p> 	<p>The instructions provided in this operating manual concern only the correct use of the system. To perform the test correctly, the user must observe the specific norms for the test.</p>
---	---

### 1.4 Guarantee

Our **General Terms of Sales and Delivery** apply in all cases.

The Manufacturer guarantees that this Operating Manual has been prepared in conformity with the technical and functional parameters of the machine as delivered. The Manufacturer reserves the right to add supplementary information to this Operating Manual as required.

The guarantee provided by the Manufacturer is the legal guarantee. This guarantee does not cover wear-and-tear parts.

The Manufacturer guarantees trouble-free operation only if the User observes the instructions in this Operating Manual, and only if the User employs the machine for the purpose for which it is intended.

The Manufacturer shall not be liable for damages that may occur if the machine is used for purposes for which it is not intended, or if the User does not observe the instructions and rules for operation as set forth in this Operating Manual.

No claims for damages may be lodged against the Manufacturer if the machine is modified in its structural or constructional characteristics without the prior written consent of the Manufacturer, or if its functional characteristics are modified without such consent.

## **1.5 Acceptance of delivery, transport**

### **1.5.1 Acceptance of delivery**

When accepting delivery of the machine, first inspect it for its outer, visible condition. If this inspection is satisfactory, the machine may be accepted from the freight forwarder (railways, parcel service, or other haulage company).

If there are no shortcomings, and if there are no transport damages, then use the bill of delivery to make sure that the consignment is complete, and that all parts have been delivered.

If you assume or suspect transport damage, or if transport damage becomes apparent only after you have accepted the delivery, immediately make an exact report of the conditions and any damage as they exist. Send us this report immediately by fax or e-mail. Important: Absolutely do not make any changes to the delivered goods.

After we have studied your report, we can make a decision whether we can:

- Deliver spare parts to you, or
- Send a specialized fitter/installer to your plant, or
- Ask that you return the system to us for repair.

### **1.5.2 Transport**

If you wish to transport the Climate-Controlled Chest to another location, or to load it onto a vehicle, you can do so manually if you wish. Or, you can stand it on a pallet vertically and pick it up with a fork-lift.

Be sure to protect the Climate-Controlled Chest at all times from the effects of the weather and climate.

The weight is approx. 60 kg.

Place the Climate-Controlled Chest on a level surface which can effectively support its weight during operation.

The ambient conditions that must be observed are as follows:

Permissible temperature conditions:	+ 15 ... 40°C
Permissible relative humidity:	30 ... 75%
Max floor load:	500 kg/m <sup>2</sup>

## 1.6 Scope of delivery



Climate-Controlled Chest, ready for operation, including:

Incl.:

Heater with controller and power-connection cable, bottom lath frame support, housing cover

## 1.7 Connection to the power supply

The ratings for the power supply of the Cabinet must be 230 V and 50 Hz.

<p>Danger</p> 	<p>The device must be connected to the building power system by a qualified electrician.</p> <p>In accordance with the pertinent standards, the yellow-green connection terminal must be attached to the earthing system before additional electrical connections are made.</p> <p>Before making the electrical connections, please study the enclosed wiring diagram. Also check the machine rating plate to make sure that the ratings of the building power supply conform to the requirements for voltage, wattage, amperage, and frequency of the device.</p> <p>The electrical socket must have a safety device that will protect the system against over-current. This safety device must satisfy the stipulations of the relevant standards, and must match the machine voltage. The technical characteristics of this safety device must also satisfy the standards that apply in the country in which the machine is installed.</p>
<p>Caution</p> 	<p>The manufacturer of the device cannot be held liable for any damages that result because the information here is not observed.</p>

## 2 Basic safety instructions

### 2.1 Obligations of the operator / user

Persons may operate the Climate-Controlled Chest without supervision only if they have fulfilled all the following requirements:

- They must be at least 18 years old.
- They must have been instructed in the proper operation of the device
- They must have received written authorization from their plant management to operate the device.

The operator of the device is responsible to ensure that he or she does not endanger himself/herself or any other persons in the operation of this equipment.

<p>Caution!</p> 	<p>If any deficiency, shortcoming, trouble, or damage to the Climate-Controlled Chest could impair its operating safety, it must be immediately shut down. It may be used again only after all sources of danger have been eliminated.</p>
---	--

### 2.2 Danger in work with the Climate-Controlled Chest

This Climate-Controlled Chest has been designed and built in accordance with the state of the engineering art and with the accepted rules of good engineering practice. The use of this Climate-Controlled Chest, however, can cause danger to life and limb of the user and third parties. It can also cause damage to mechanical parts or to other objects.

To prevent such damage, the Climate-Controlled Chest may be used only:

- For the purposes for which it was intended (see Section above)
- If it is in completely satisfactory technical condition with regard to safety in operation.

If there are any malfunctions or other trouble that could cause dangerous situations to arise in work with the Climate-Controlled Chest, these difficulties must be immediately corrected before working with the device.

### 2.3 Regular checks

The devices/machines must be checked for their industrial safety at regular intervals. There are national regulations for this that must be complied with.

### 2.4 Information about the CE symbol

TESTING Bluhm & Feuerherdt GmbH testing devices carry the CE symbol.

The CE marking confirms that the product conforms with the EC Directives that must be taken into consideration for the product and also that the product is in compliance with the “essential requirements” that are defined therein, and the defined general relevant level of

protection. The conformity-assessment procedure has in each case been carried out in accordance with the applicable EC Directives. Decisive here is Council Decision to be used in the technical harmonisation directives for the various phases of the conformity-assessment procedure and the regulations for the mounting and usage of the CE mark.

### 3. Technical data

#### 3.1 Description of the Climate-Controlled Chest

The exterior vessel and the cover of the Climate-Controlled Chest consist of aluminium 3 mm thick. The interior vessel and the bottom grate are made of stainless steel 1.5 mm thick.

The high-quality insulation, 30 mm thick on all sides, assures very low loss of heat.

A ball valve with a ½" hose connection is installed at the bottom drain.

This system is intended for operation in dry rooms.

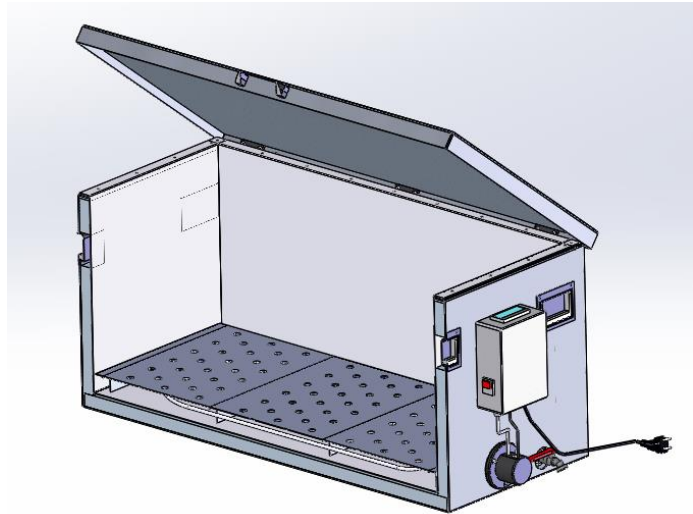

External dimensions:	approx. 1180 x 630 x 520 mm
Internal dimensions:	approx. 1000 x 500 x 415 mm
Maximum water level over the bottom lath frame support:	375 mm
Weight, empty:	300 kg
	approx. 62 kg

#### 3.2 Electrical features

The power supply for the Climate-Controlled Chest must be 230 V / 50 ... 60 Hz.

The heating resistor and the temperature sensor are installed under the bottom lath frame support, to protect them from mechanical damage.

The temperature sensor is located in a tube.

An electronic temperature controller regulates the correct temperature.

The Climate-Controlled Chest is connected to the power supply by a two-pole and earthing-pin plug. The dual-pole main switch turns the Climate-Controlled Chest off and on.

When it is in the ON position, the control lamp of the main switch lights up.

An additional lamp on the control display signals the heating mode.

#### 2.3 Technical data

Power ratings:	230 V and 50 ... 60 Hz
Power consumption:	Max. 1100 W
Class of enclosure protection:	IP 54



## 4. Placing the Climate-Controlled Chest into operation

<b>Attention</b> 	We strongly recommend that you use a residual-current-operated circuit-breaker (RCCB; also known as earth-leakage circuit-breaker, ELCB) with this Climate-Controlled Chest. This device should have a fault-current tripping rating of 30 mA.
	Failure to comply with the instructions that are described could cause electric shocks, fires and/or serious injuries.

Place the Climate-Controlled Chest on a level surface which can effectively support its weight during operation. The loadbearing capacity of this support should be at least 500 kg. The main switch is switched off. Do the main connection.

### 4.1 General recurring operating steps

Open the cover.

Place the concrete samples into the machine. Fill with water. The maximum water level is approx. 4 cm below the upper edge of the water basin. The water must completely cover the concrete samples.

Close the cover

Switch on the main switch on the controller enclosure.

When the red signal lamp shows, the machine is in operation. The controller shows the actual temperature being measured.

Check the required temperature on the temperature controller by quickly pressing the ▲ or ▼ buttons. If necessary, change the required temperature value as described in the following instructions.

*When the Climate-Controlled Chest is delivered, its default temperature is set to the required value (setpoint) of 20 °C.*

Your Climate-Controlled Chest is now ready for operation.

<b>Caution</b> 	Never operate the Climate-Controlled Chest without water. This will damage the tubular heating element.
---	---

## 4.2 Description of the temperature controller

The controller is a universally applicable controller with one (1) relay output. It has the following features:

- Control range with PTC sensor:  $-35^{\circ}\text{C} \dots +105^{\circ}\text{C}$
- Temperature units: in degrees Celsius (centigrade)
- Resolution of the display: 0.1 K
- Controller mode: 2-point, ON/OFF
- Front-side, digital input of required values and function parameters
- Data safeguarding even in case of mains power failure
- Alarm display in case of sensor malfunctions.

## 4.3 Displays

Under normal conditions, the display will show the momentary temperature as measured by the immersion sensor.

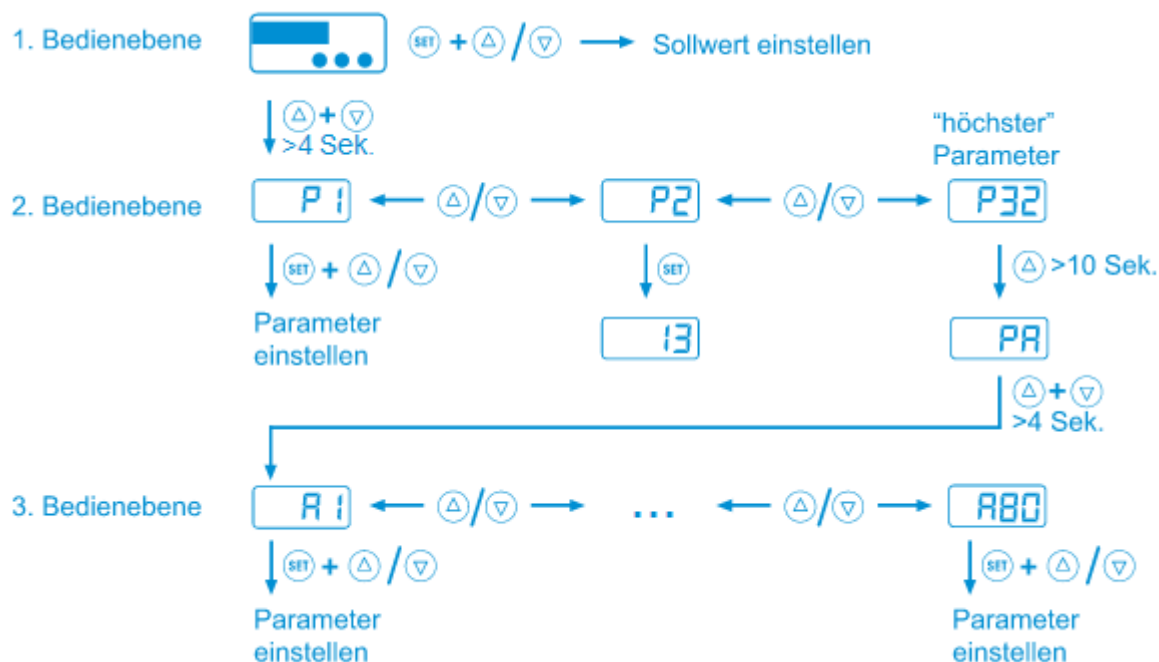

Button functions to show and change the setpoint values (specified values):

To show the setpoint value:

Press the "SET" button once

To change the setpoint value:

Press the "SET" button and hold it down ...

... then:

To increase the setpoint value, press the ▲ button

To decrease the setpoint value, press the ▼ button

After you release the buttons, the newly set value will be stored in the non-volatile memory. The setting of the new setpoint value (required value) is now finished.

The delay feature in the setting function protects the user from accidentally changing values.

**At the factory, the temperature setpoint is set to the default temperature of 20 °C.**

#### 4.4 Messages and warnings on the display

Message	Description	Action to be taken
OFF	Standby mode. There are no control functions.	Switch on by pressing the standby-button
F1L	Sensor fault or short circuit.	Check the sensors and the sensor connection terminals.
F1H	Sensor fault or breakage in the sensor.	Check the sensors and the sensor connection terminals.
	The keyboard locking function is active.	See Parameter P19 or A19.
The display is flashing	Temperature alarm (see A31)	
The acoustic alarm sounds (buzzer)	Temperature alarm (see A31)	Shut off the acoustic alarm (buzzer) by pressing the DOWN button.
EP	Data loss in parameter memory (control-contacts no. 1 and 2 are without current)	Switch the mains power OFF, then ON again. If this does not solve the problem, the controller must be repaired.

Sensor error messages are saved and will continue to be shown, even if the cause of the problem has been corrected. If you acknowledge these error messages by pushing the DOWN button, this will delete the error message.

## 4.5 Setting the control parameters (P level)

Parameter name in the display	Range for settings entered	Default setting by TESTING
P2 Hysteresis K1	0.5 ... 20 K	0.5 K
P4 Minimum setpoint limit	-40 ... 110 °C	18°C
P5 Maximum setpoint limit	-40 ... 110 °C	22°C
P6 Actual-value correction	-40 ... 40 K	0 K
P19 Locking the buttons	0 = not locked 1 = locked	0
P30 Lower limit value for alarm	-99 ... 999°C	-99°C
P31 Upper limit value for alarm	-99 ... 999 °C	100°C
P32 Hysteresis for alarm values	0.5 ... 99.9 K	1.0 K
d0 Thawing interval	0 ... 99 h 0 = no thawing	0
d2 Thawing temperature limit	-99.0 ... 999°C	10.0°C
d3 Thawing time limit	0 ... 99 min 0 = without time limit	30 min

### Return to normal operating state:

You can place the system back into its normal operating condition by briefly switching off the power supply and switching it back on.

Or: if you make no changes in the P parameters for approx. 60 seconds, the controller will automatically switch over into the operational mode.

### Setting of setpoints (required values):

Switch on the power supply. Press the SET button and use the ▲ or the ▼ button on the controller to set the setpoint in the setpoint limit range P4 and P5. The default setting from the factory is 20 °C.

If the user heats the water to a temperature higher than the default required temperature set at the manufacturer's plant (20 °C), this can place an additional load on the Climate-Controlled Chest and can shorten the service life of the tubular heating element.

### Calibration of the sensor (correction of the setpoint value):

You can calibrate the temperature sensor as follows: Measure the actual temperature with a calibrated measuring device.

Compare this measured temperature with the temperature shown on the display of the controller.

Set the positive or negative temperature difference in parameter P6.



The controller will then use this temperature difference to perform an automatic correction of the actually measured value, over the entire measuring range.

## 5. Maintenance and emptying

The Climate-Controlled Chest requires practically no maintenance.

To assure free drainage of water, remove residue pieces from the test specimens from the drain line and from the ball valve.

Regular inspections and maintenance will maintain the functionality of the devices.

<p>Note</p> 	<p>For movable electrical equipment, the German accident-prevention regulation requires that measurements be conducted at intervals of approximately every six (6) months in accordance with the regulation VDE 0701, Sections 1 to 4.</p>
<p>Attention</p> 	<p>Before maintenance work is carried out, ensure that the device cannot be turned on again unintentionally by switching the device off and disconnecting it from the power supply.</p>

The inside surfaces can be cleaned with dilute citric acid / vinegar. Finally, clean with clear water.

## 6. Troubleshooting

<p>Caution</p> 	<p>Work on such electrical equipment may be performed only by suitably trained specialist personnel. In case of malfunction, disconnect the Climate-Controlled Chest from the power supply.</p>
--	---

In the event of a fault, the system must be disconnected from the supply network.

Message	Description	Action to be taken
OFF	Standby mode. There are no control functions.	Switch on by pressing the standby-button
F1L	Sensor fault or short circuit.	Check the sensors and the sensor connection terminals.
F1H	Sensor fault or breakage in the sensor.	Check the sensors and the sensor connection terminals.
	The keyboard locking function is active.	See Parameter P19 or A19.
The display is flashing	Temperature alarm (see A31)	
The acoustic alarm sounds (buzzer)	Temperature alarm (see A31)	Shut off the acoustic alarm (buzzer) by pressing the DOWN button.
EP	Data loss in parameter memory (control-contacts no. 1 and 2 are without current)	Switch the mains power OFF, then ON again. If this does not solve the problem, the controller must be repaired.

## **7. After-sales service**

Great care was taken to assure that this Operating Manual was properly prepared. We cannot, however, guarantee that it has no mistakes, or that all data are complete and correct in the event of technical modifications.

### **7.1 Date of this version of the Operating Manual**

Version no. 5  
Jun. 2013

### **7.2 Copyright**

The copyright to this Operating Manual is held by:

TESTING Bluhm & Feuerherdt GmbH

This Operating Manual is intended for use only by the User and his/her staff. It contains instructions and data that may NOT be:

- Reproduced,
- Distributed, or
- Provided to any third party.

Any person acting in violation of the above stipulations may be prosecuted before a court of law.

### **7.3 Spare parts and technical help**

If you have any questions of technical nature, or if you need spare parts, please get in touch with the following address:

TESTING Bluhm & Feuerherdt GmbH  
Motzener Str. 26b  
DE – 12277 Berlin  
Germany

Tel. [+ 49 30] 710 96 45-0  
Fax [+ 49 30] 710 96 45 98  
[www.testing.de](http://www.testing.de)  
[info@testing.de](mailto:info@testing.de)

**EC Declaration of Conformity in accordance with the Machinery Directive  
2006/42/EC Appendix II 1.A**

The authorised representative established in the community,

Mr. Feuerherdt

hereby declares that the following product

Manufacturer: TESTING Bluhm & Feuerherdt GmbH  
Motzener Str. 26b  
12277 Berlin  
Product designation: Climate-Controlled Chest- stainless stell/aluminum  
Serial number: continuous  
Serial/Type designation: 2.0401

complies with all of the relevant provisions of the above named guidelines as well as the additional applied guidelines (following) - including any of the amendments thereto which are in force at the time of the declaration.

The following additional EU Directives have been applied:

Low Voltage Directive 2014/35/EC

The following harmonised standards have been applied:

DIN EN 60204-1 The Safety of Machines - Electrical Equipment of Machines - Part 1:  
General Requirements (corrigendum 2010)  
DIN EN ISO 12100 Safety of machinery - General principles for design - Risk assess-  
ment and risk reduction (corrigendum 2013)

The name and address of the person who has been authorised to compile the technical docu-  
mentation:

Mr. Metge

Location: Berlin  
Date: 28/02/2014



(Signature)  
Managing Director



(Signature)  
Technician

