

Operating Manual

Cabinet for Moist Storage of Mortar Prisms in Triple Moulds

In accordance with EN 196

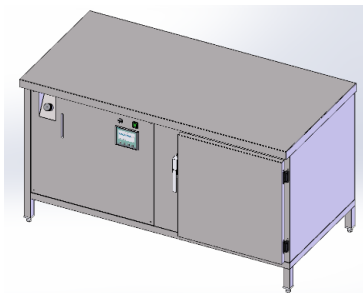

1.0321.03

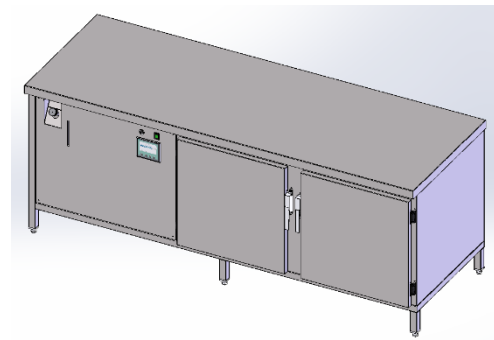

1.0321.04

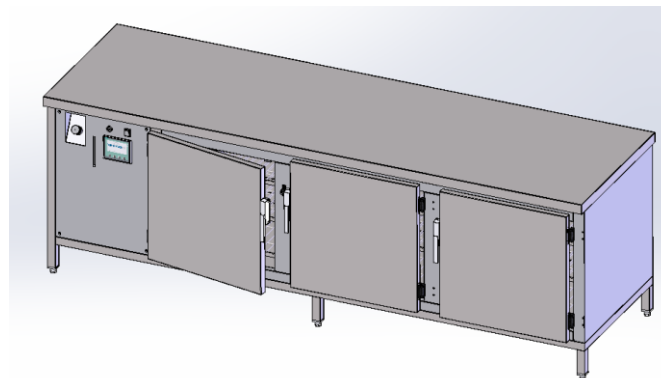

1.0321.05

CAUTION: Do not place this device into operation until you have made yourself fully acquainted with its connection, with its function, and with the position of all its control elements and functions.

Contents	Page:
1. Basic instructions	3
1.1 Designation.....	3
1.2 Purpose for which this system was designed.....	3
1.3 Conditions under which this system may NOT be used.....	4
1.4 Guarantee.....	5
1.5 Safety instructions.....	5
1.6 Acceptance of delivery and transport.....	6
1.7 Setting up the Cabinet.....	7
2. Placing the Cabinet into operation	8
2.1 General information	8
2.2 Humidifier.....	8
2.3 Drain for condensation water	8
2.4 Connection to the power supply	9
2.5 Shelves of the Cabinet.....	10
2.6 Switching on the Cabinet	10
3. Characteristics of the system	11
3.1 General description of the system.....	11
3.2 Technical data	11
4 Open- and closed-loop control equipment	12
4.1 Home display	14
4.2 Normal display	14
4.3 Parameterization.....	15
4.4 Function check.....	16
4.5 Data record management	17
4.6 Extras	18
4.7 Messages and warnings on the display.....	19
4.8 Calibration of the display value	20
5. The humidification system	21
6. Maintenance, care, and cleaning of the system	22
6.1 General instructions	22
6.2 Care of the indicator instruments	23
6.3 Care of the humidifier.....	23
7. Troubleshooting	24
8. Placing the system out of operation.....	25
9. Scrapping the system	25
10. After-sales service	26
10.1 Date of this version of the Operating Manual	26
10.2 Copyright	26
10.3 Spare parts and technical help.....	26

Attachments:

- Circuit diagram
- Hydraulic diagram
- Declaration of conformity
- Record of measurement and testing at the manufacturer's plant
- Record of temp. and humidity

1. Basic instructions

1.1 Designation

Designation of the device: Please see the name plate on the cabinet, which shows the complete characteristic data and the electric properties of the system.

1.2 Purpose for which this system was designed

This Operating Manual contains the information required for operation of the products described here, for the purpose for which they have been designed. This Operating Manual is intended to be used only by technically qualified staff.

“Technically qualified staff” is defined as those persons who – as a result of their training; their experience; the instructions which they have received; as well as their knowledge of the relevant standards, regulations, accident-prevention regulations, and conditions of product operation in the company – have been authorized by the person responsible for the safety of the company equipment to carry out the activities and actions required for operation of the equipment described below, and who can recognize and prevent any possible dangers arising from such operation (this definition of technically qualified staff has been provided).

The User must by all means observe the requirements and limit values, as well as all safety instructions, given in this Operating Manual. Any use of this device not in conformity with these stipulations shall be considered to be in violation of the use for which this system was intended. If this device must be operated under special conditions, or with special modes of operation, then this shall be authorized only after consultation with the manufacturer, and after obtaining his prior and express approval.



This Cabinet is intended for storage of test specimens in accordance with EN 196, in triple Moulds. These standards stipulate a temperature of $20 \pm 1^\circ\text{C}$ and a relative humidity $> 90\%$ for storage of such Moulds. The Cabinet has been set at the manufacturer’s plant to conform with these conditions.

<p>Caution</p> 	<p>The instructions contained in this Operating Manual are intended only for the correct use of the Cabinet for Moist Storage of Mortar Prisms in Triple Moulds. In order to perform the necessary testing correctly, the User must observe the specific standards for such testing.</p>
--	--

- This Operating Manual is intended to be read and followed by the freight carrier, the fitters and installers, the Operators and Users, the service and repair staff, and the persons who must dispose of (scrap) the system.
- It is absolutely necessary to read and understand all the instructions in this Operating Manual in order to operate this Cabinet properly and safely.
- This Operating Manual must be considered as a constituent component of the product. It may be used only together with the system with which it has been delivered.

- This Operating Manual must be kept closely at hand and in good condition throughout the entire service life of the machine. It must be immediately available whenever it is needed.
- If this Cabinet is sold, the Operating Manual must be passed on to the new owner.
- The Manufacturer may not be held liable for any damages that arise as a result of improper use or handling of the Cabinet.
- The Manufacturer reserves the right to modify this technical manual, as well as the machines that it refers to, without prior notice.

The Caution and Danger alerts have the following meaning:

<p>Caution</p> 	<p>This warning refers to dangers that could cause material damage.</p>
<p>Danger</p> 	<p>This warning refers to dangers that could cause severe injuries or even fatalities.</p>
<p>Note</p> 	<p>Provides practical advice on operation</p>

1.3 Conditions under which this system may NOT be used

This Cabinet was not intended for use under the following conditions. It may therefore NOT be used under such conditions or for the following purposes:

- This Cabinet may not be used to store explosive or chemical substances.
- Do not disassemble this system. Do not try to repair it or to modify it.
- Operate this product only with an electrical system which satisfies the ratings for voltage and current as given in this Operating Manual.
- Do not cover this Cabinet. There must be sufficient open space above the Cabinet so that the heat from the system can properly dissipate into the surroundings.
- Do not operate the Cabinet in locations which are subject to the following conditions or substances: Ice formation, Heat radiation, Formation of condensation water, Dust, Corrosive gases, Vibrations, Severe physical impact (jolts), High relative humidity, Temperature fluctuations

1.4 Guarantee

Our **General Terms of Sales and Delivery** apply in all cases.

The Manufacturer guarantees that this Operating Manual has been prepared in conformity with the technical and functional parameters of the Cabinet as delivered. The Manufacturer reserves the right to add supplementary information to this Operating Manual as required.

The guarantee provided by the Manufacturer is the legal guarantee. This guarantee does not cover wear-and-tear parts.

The Manufacturer guarantees trouble-free operation only if the User observes the instructions in this Operating Manual, and only if the User employs the Cabinet for the purpose for which it is intended.

The Manufacturer shall not be liable for damages that may occur if the Cabinet is used for purposes for which it is not intended, or if the User does not observe the instructions and rules for operation as set forth in this Operating Manual.

No claims for damages may be lodged against the Manufacturer if the Cabinet is modified in its structural or constructional characteristics without the prior written consent of the Manufacturer, or if its functional characteristics are modified without such consent.

1.5 Safety instructions

Only those persons may independently operate the Cabinet who have received sufficient training in the operation of this system.

This Cabinet has been designed and built in accordance with the state of the engineering art and the recognized rules of good engineering practice. At the same time, however, dangers can arise during its operation, and damage to the electrical components can occur.

Before putting this system into operation, check to make sure that the ratings of your mains power voltage and current are the same as the electrical data specified on the rating plate (nameplate). Connect this Cabinet **only to alternating current (AC)**.

Use this Cabinet only for the purpose that has been described in this Operating Manual. If this system is improperly used, or used for purposes for which it was not intended, the guarantee will not be valid.

If the Cabinet or its power cable are damaged, immediately pull out the power plug. If shortcomings or damages to the Cabinet occur that impair its operational safety, the system must immediately be taken out of operation. It may be put back into operation only after all sources of danger have been eliminated. The Cabinet has been provided with two internal automatic circuit breakers (automatic cutouts) to prevent electrical problems.

1.6 Acceptance of delivery and transport

Acceptance of delivery

When accepting delivery of the Cabinet for Moist Storage of Mortar Prisms in Triple Moulds, first inspect it for its outer, visible condition. If this inspection is satisfactory, the machine may be accepted from the freight forwarder (railways, parcel service, or other haulage company).

If there are no shortcomings, and if there are no transport damages, then use the bill of delivery to make sure that the consignment is complete, and that all parts have been delivered.

If you assume or suspect transport damage, or if transport damage becomes apparent only after you have accepted the delivery, immediately make an exact report of the conditions and any damage as they exist. Send us this report immediately by fax or e-mail. Important: Absolutely do not make any changes to the delivered goods.

After we have studied your report, we can make a decision whether we can:

- Deliver spare parts to you, or
- Send a specialized fitter/installer to your plant, or
- Ask that you return the system to us for repair.

Transport

The Cabinet is delivered on a wooden frame.

You can move the Cabinet to its place of installation by leaving it on the wooden frame and by moving it with a fork-lift truck or other suitable transport equipment. It is necessary for this equipment to reach under the wooden frame to move the Cabinet to its intended location.

Do not use cables or ropes wrapped around the equipment, or any similar lifting apparatus, to lift the system – unless you can assure that lateral forces will not act on the packing from the side or on any parts of the system while it is being lifted.

The weight of the equipment is approx. 1.0321.03 ca. 250 kg
1.0321.04 ca. 350 kg
1.0321.05 ca. 420 kg

<p>Caution</p> 	<p>Be careful not to knock or bump against the Cabinet. Be sure that it cannot fall over.</p>
--	---

After you have unpacked the Cabinet for Moist Storage of Mortar Prisms in Triple Moulds, make sure that the system has not been damaged during transport. If you are not sure whether the machine has been damaged or not, get in touch with the person who sold you the system.

<p>Note</p> 	<p>Before you dispose of the packing material, be sure not to leave any of the following items in the packing: accessory parts, printed instructions, documents, or spare parts.</p>
---	--

1.7 Setting up the Cabinet

Set up the Cabinet for Moist Storage of Triple Moulds on a surface that is level, that is not subject to vibrations, and that can sufficiently support the weight of the cabinet. Now level the cabinet.

The ambient conditions that must be observed are as follows:

Permissible temperature conditions:	+ 15 ... 35°C
Permissible relative humidity:	30 ... 75%
Maximum elevation:	1,000 metres above sea level
A room that can sufficiently support the weight of the cabinet:	The total weight (mass) of the Cabinet is approx. 800 kg (gross).
provide the required humidity in the Cabinet	Use of internal tank with distilled water
Electrical ratings:	Acc. Standard VDE 0510 230 V and 50 Hz, with fusegear (circuit breaker) rated at 16 A.

There is a ½" connection (yellow hose) for draining off the that collects inside the Cabinet. The connection must lie low enough to allow the water to flow out without difficulty. The connection must not be higher than 10 cm above the floor. It is also possible, as an alternative, to use a bucket with a capacity of approx. 5 litres.

The yellow hose must be routed to the outside to ensure drainage.

You will require the following equipment to set up the Cabinet for Moist Storage of Mortar Prisms in Triple Moulds:

- A fork-lift truck with a lift distance of at least 200 mm
- A water level (spirit level)

The main working position of the Operator will be in front of the Cabinet. The Cabinet must be set up in such a way that it is open to easy access from the front and on both sides. This will allow maintenance work to be conducted without difficulty. At the rear, the Cabinet must have approx. 100 mm clearance from the wall. The Cabinet should also be installed as far as possible away from any sources of heat or cold. Make sure that air can freely circulate around the lower supporting structure of the Cabinet: this means **not** placing any objects near the Cabinet, to the front and back, or to the sides.

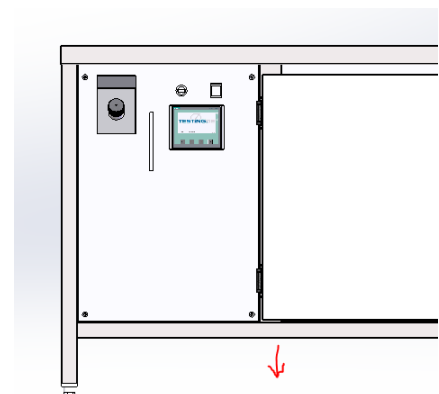

2. Placing the Cabinet into operation

2.1 General information

To place the Cabinet into operation, you need the following:

- A room with a floor that can sufficiently support the total weight of approx. 800 kg (gross weight)
- Distilled water acc. Standard VDE 0510 to provide the required humidity
- Electric power connection with 230 V and 50 Hz, and with fusegear (circuit breaker) rated at 16 A

<p>Note</p> 	<p>Before being put into operation, the Cabinet must remain unused for at least one (1) day at the place where it will operate. This time is necessary for it to adapt to the local ambient conditions.</p>
---	---

2.2 Humidifier

An internal water tank filled with distilled water is used to feed the Cabinet. The water tank (10 litres) is installed inside the Cabinet. This tank is filled through a filling opening with a stopper, which is located on the front side of the Humidity workbench. You must regularly check the filling level of the Cabinet to ensure that enough distilled water is in it. An inspection window on the front side of the Humidity workbench shows how much water is left in the tank. Do not allow the level of the water to fall below the lowest section of this window.

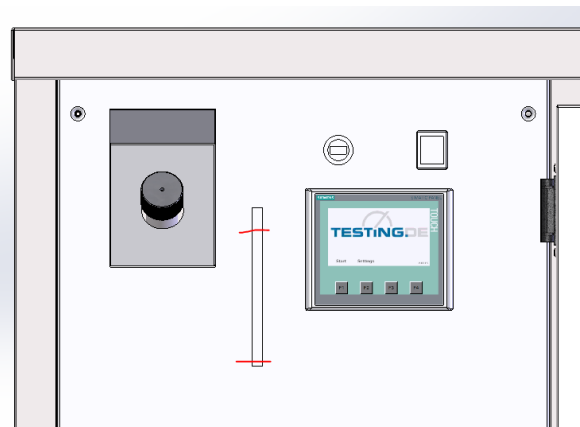



2.3 Drain for condensation water

There is a ½" connection (yellow hose) for draining off the that collects inside the Humidity workbench for Moist Storage of Mortar Prisms in Triple Moulds. The connection must lie low enough to allow the water to flow out without difficulty. The connection must not be higher than 10 cm above the floor. It is also possible, as an alternative, to use a bucket with a capacity of approx. 5 litres, and to insert the end of the drain hose into this bucket. If the Humidity workbench is used on a daily basis, be sure to regularly check the level of water in this bucket.

2.4 Connection to the power supply

The Cabinet has a 3-core power cable that is 2.0 metres long. The ratings for the power supply of the Cabinet must be 230 V and 50 Hz.

<p>Danger</p> 	<p>The Cabinet must be connected to the building power system by a qualified electrician.</p> <p>In accordance with the pertinent standards, the yellow-green connection terminal must be attached to the earthing system before additional electrical connections are made.</p> <p>Before making the electrical connections, please study the enclosed wiring diagram. Also check the machine rating plate to make sure that the ratings of the building power supply conform to the requirements for voltage, wattage, amperage, and frequency of the Cabinet for Moist Storage of Mortar Prisms in Triple Moulds.</p> <p>The electrical socket must have a safety device that will protect the system against over-current. This safety device must satisfy the stipulations of the relevant standards, and must match the machine voltage. The technical characteristics of this safety device must also satisfy the standards that apply in the country in which the machine is installed.</p>
<p>Caution</p> 	<p>The manufacturer of this Cabinet cannot be held liable for any damages that result because the information here is not observed.</p>

Electrical tolerances:

Actual voltage: $\pm 10\%$ of the rated voltage

Frequency: 50 Hertz $\pm 1\%$ of the rated frequency, continually; $\pm 2\%$ of the rated frequency, on a short-term basis

The manufacturer shall not be liable for damages to persons or property that arise because the above instructions have not been observed.

We recommend the use of a residual-current-operated circuit-breaker (RCCB) with 30-mA rated residual-current trip.

The system must be connected to the electric mains power system.

For purpose of safety, the system should be separately fuse-protected with 16 A.

2.5 Shelves of the Cabinet

<p>Danger</p> 	<p>When you are loading the shelves of the Cabinet, make sure that you pull out only one (1) shelf at a time. If all the shelves are full, and if you pull out all the shelves, there is a danger that the Cabinet will fall over toward the front.</p>
---	---

2.6 Switching on the Cabinet

<p>Note</p> 	<p>First, the temperature in the Cabinet must be regulated to the required level. Then the relative humidity in the Cabinet will reach the level as set by you. When you switch the Cabinet on, the default settings from the factory are as follows: the left controller is active, and the right controller is deactivated.</p>
---	---

1. Switch on the main switch. This will automatically regulate the temperature inside the Cabinet to 20°C.
2. When the temperature has reached the set level, then press the standby button on the right-hand controller. This will activate the control function for the humidification of the air.
3. If the humidity does not begin to rise, then there is no water supply. The following reasons can mean that there is no water supply:
 - There is no distilled water in the tank, or there is not enough water.
 - There is a kink (i.e., a twist or curl) in the water-supply hose. Please straighten out the hose so that the water can flow freely. The water hose has a leak. Repair the leak.
 - The humidifier is not switched on. Turn on the humidifier.
 - Bleed the water line. To do this, open the front cover and squeeze the hose, that the air bubbles go out.



After following the steps above, use an external, officially calibrated testing system to measure the exact temperature and humidity inside the Cabinet for Moist Storage of Mortar Prisms in Triple Moulds. If the officially calibrated testing system measures values that are different from the display on the controller, you must use a correction factor in the controller to change the display reading to match the actually measured values.

The Cabinet is now ready for operation.

3. Characteristics of the system

3.1 General description of the system

The purpose of the Cabinet is to store test samples of mortar prisms in triple moulds, in accordance with EN 196, for use in laboratory and research work. Standard EN 196 stipulates a temperature of $20^{\circ}\text{C} \pm 1^{\circ}\text{C}$ and a humidity $> 90\%$.

The Cabinet has a double wall, with heat insulation between the walls. It is primarily constructed of stainless-steel plate. It has an upper and a lower part. The upper part serves as a climate-controlled storage chamber, and the lower part contains the technical equipment for operating the Cabinet.

The Cabinet maintains the conditions at the required temperature and humidity by systems that heat or cool, and that humidify or dehumidify the air inside the Cabinet.

During operation, water may collect inside the Cabinet. This condensed water can be drained out of the Cabinet, through a drain pipe, into a collection tank (this tank is not included in the scope of delivery). Or, the water can be drained out of the Cabinet into the normal drain-pipe system of the building.

3.2 Technical data

Power ratings:	230 V AC, 50 Hz, max. 1.2 kW
Hysteresis:	As required, by setting the switch-on or switch-off points
Display resolution of control:	$\pm 0.1^{\circ}\text{C} / \pm 1\% \text{ r.H.}$
Degree of enclosure protection:	IP 54, in accordance with DIN 40050 and ICE 144 (the front is protected by membrane keypad)
Enclosure protection class:	Class 2, in accordance with VDE 0100
Storage capacity:	maximum of 4 ea. triple moulds per shelf 1.0321.03 12 moulds 1.0321.04 24 moulds 1.0321.05 36 moulds
Max. load capacity per shelf:	60 kg
Controlled temp. / humidity:	$20^{\circ}\text{C} \pm 1^{\circ}\text{C} / > 90\% \text{ r.H.}$
Dimensions:	1.0321.03 = 1600mm x 800mm x 900mm 1.0321.04 = 2250mm x 800mm x 900mm 1.0321.05 = 2650mm x 800mm x 900mm
Weight (mass) of the Cabinet:	Approx. 250 - 420 kg
Maximum water consumption:	1 litre per day (it is not possible to provide an exact value here, since the water consumption will depend, for example, on the type of sample material in the Cabinet and on the laboratory-room temperature)

The Cabinet operates with the refrigerant R134a, which does not contain chlorofluorocarbons (CFC's).

The Cabinet belongs to those types of work equipment whose noise emissions generally do not reach a rating level of 85 db(A) as stipulated in DIN 45 635. The level of noise produced by the particular Cabinet will depend on various factors: e.g., on the product, the place where it is in operation, and other equipment installed near the Cabinet.

Sound-pressure equivalent (A) at the workplace:	20 dB(A)
Standards that apply to the data given above:	EN ISO 3746

For the reasons given above, it is not possible to provide a sound-pressure level that is generally valid for this Cabinet. For further information, please consult the guidelines, directives, and standards that apply in the country in which the Cabinet will be operated.

The manufacturer will test and calibrate the Cabinet before it is delivered. The measuring equipment used for this testing and calibration is checked for accuracy at regular intervals by state institutes.

Note 	Currently valid standards stipulate that the Cabinet must be tested for proper calibration every time the Cabinet is moved to another place of operation.
---	---

4 Open- and closed-loop control equipment

The Cabinet automatically controls the temperature and humidity to the values set by the User. It is not necessary for the user to make manual changes to the temperature and humidity.

Note 	When the Cabinet is installed for the first time, and whenever it is put back into operation after not being used for a long time, the Cabinet will require at least one (1) day before the temperature and humidity settle down to the desired settings.
---	---

The open- and closed-loop control equipment installed in the Cabinet was developed for control systems in which several outputs are required.

The Touch-display with 4 membrane keyboard keys is used to input the settings for the required values (setpoints), the standby values, and all other parameters for the controlling.

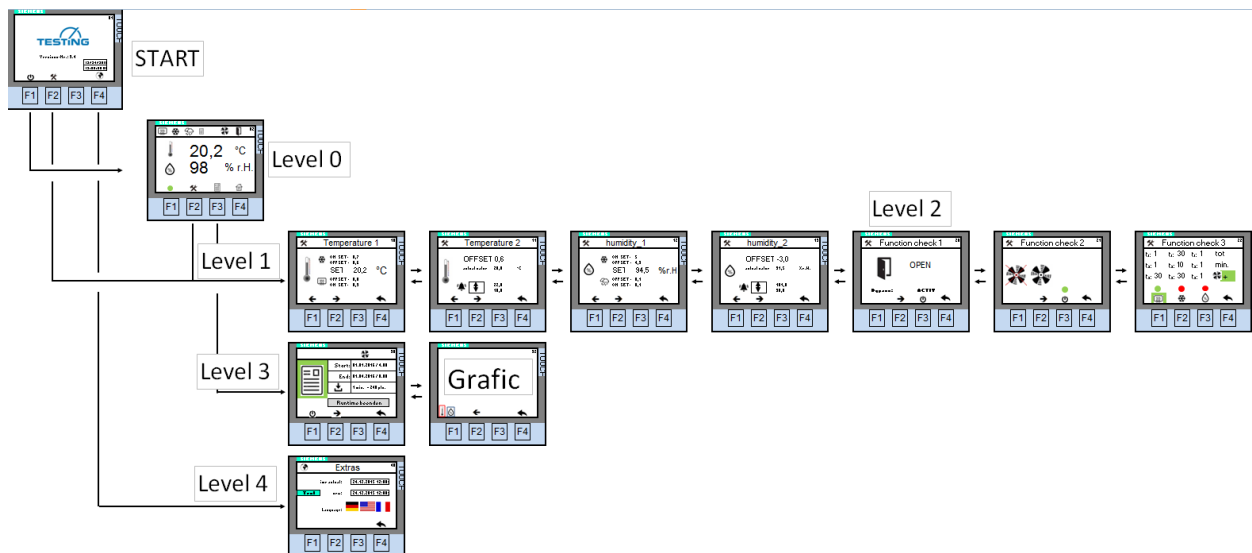
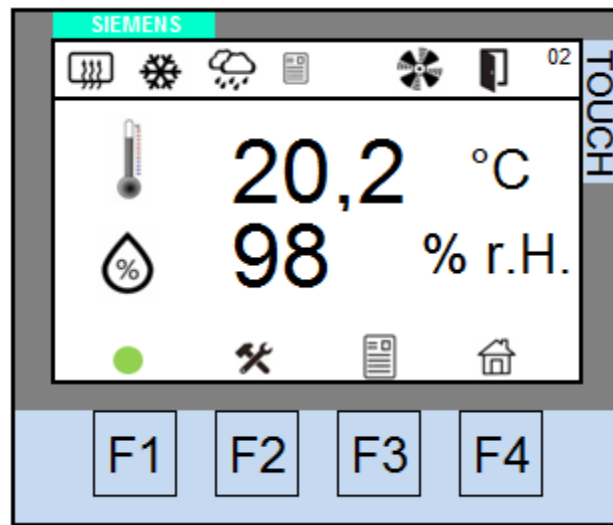

The controller has four operation levels

- START Home Display after switch on
- Level 0 Normal display
- Level 1 Level for parameter settings
- Level 2 Manual test level
- Level 3 Level for data record
- Level 4 Level for time and language settings

4.1 Home display

Page 01

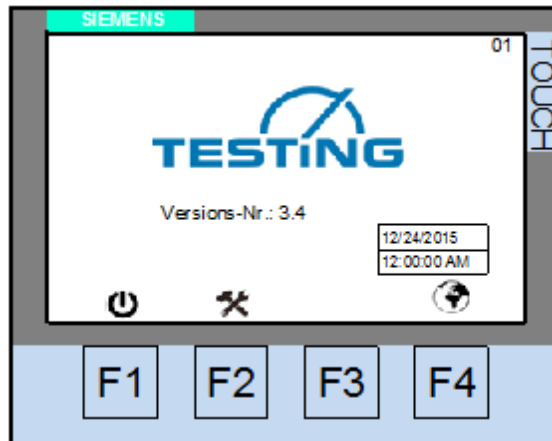

- F1 Change to NORMAL DISPLAY
- F2 Change to SETTINGS
- F3 Change to EXTRAS

4.2 Normal display

Page 02

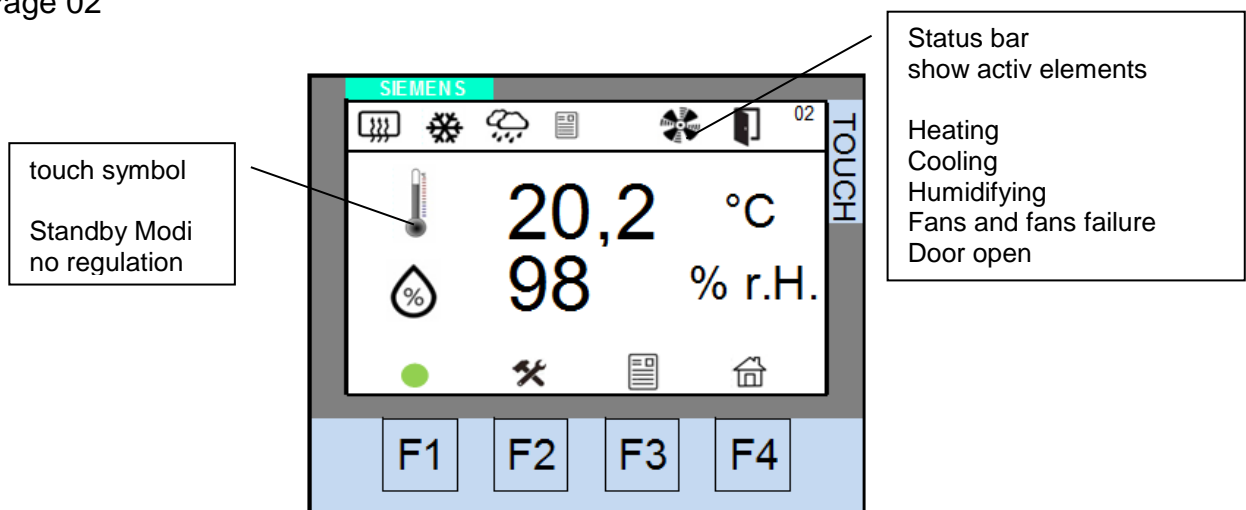

- F1 Start REGULATION
- F2 Change to SETTINGS
- F3 Change to DATA RECORD
- F4 Change to HOME DISPLAY

4.3 Parameterization

Page 11-13

Parameterization of the setpoint value. You can directly select the setpoint value for heating, cooling, humidifying and dehumidifying. You can increase or decrease the setpoint values. The newly set values will then apply for the control functions.

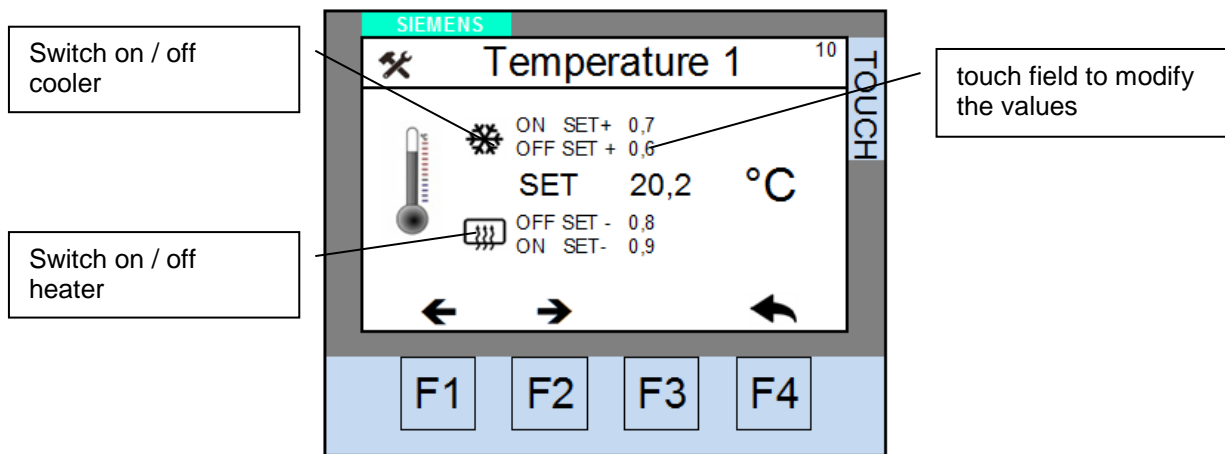

- F1 Previous display
- F2 Next display
- F4 Escape to normal display (page 02)

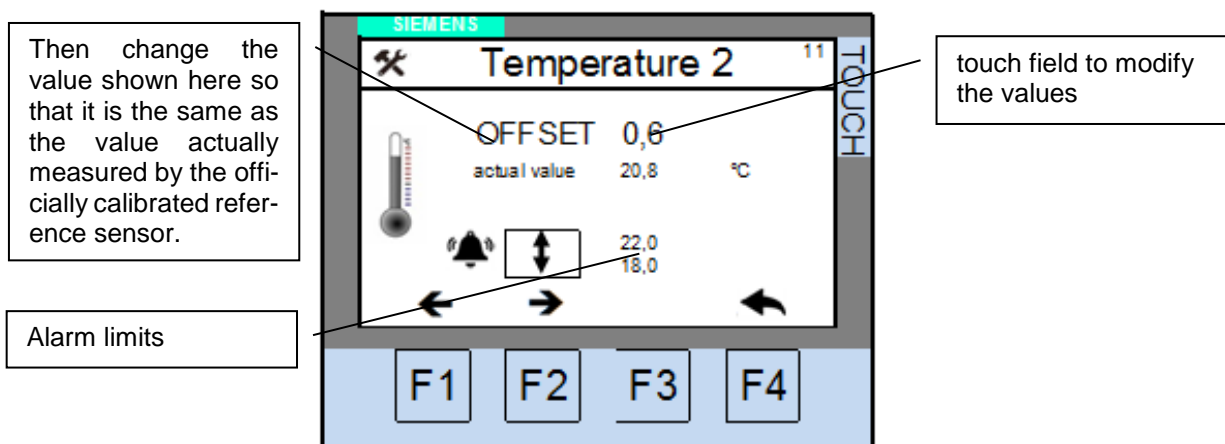

- F1 Previous display
- F2 Next display
- F4 Escape to normal display (page 02)

4.4 Function check

Here you can switch on/off all elements individually for a function test. The regulation must be switched off.

Page 20

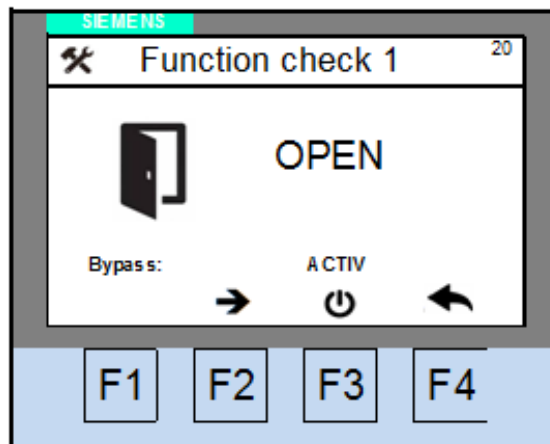

- F1 without function
- F2 Next display
- F3 ON / OFF door sensor signal bypass
- F4 Escape to normal display (page 02)

Page 21

Symbol for no fan rotation

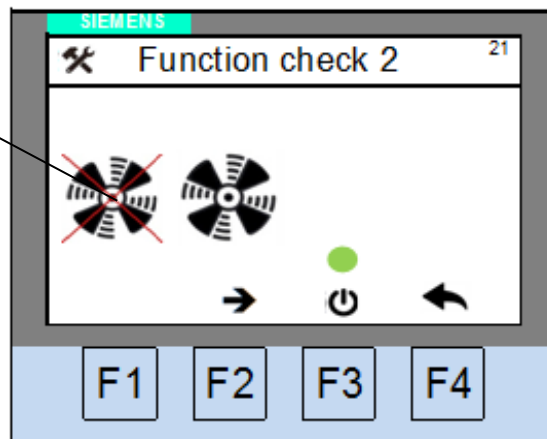

- F1 without function
- F2 Next display
- F3 ON / OFF fans
- F4 Escape to normal display (page 02)

<p>Caution</p> 	<p>The fans must be in good conditions in order to maintain a good air circulation. Please substitute defective fans.</p>
--	---

Page 22

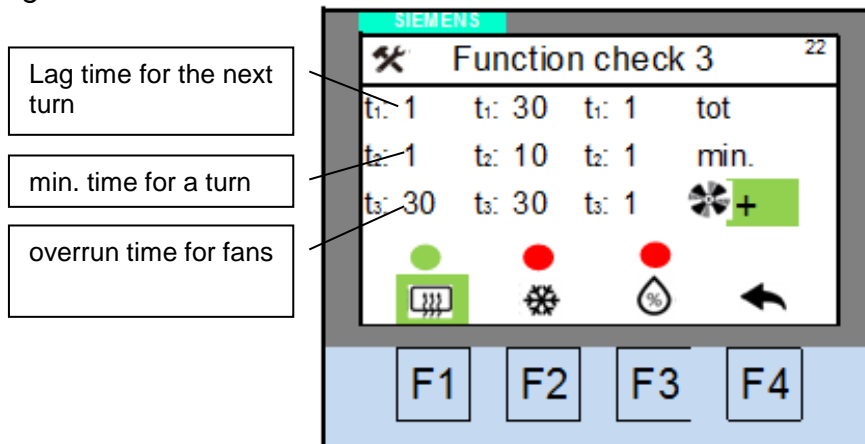

- F1 ON / OFF for heating
- F2 ON / OFF for cooling
- F3 ON / OFF for humidity
- F4 Escape to normal display (page 02)

4.5 Data record management

Here you can switch on/off the data record. A record is always possible, with or without climate regulation. The data is permanently saved automatically on an internal Storage-Card SD. For data transfer change to the onboard operating system WINDOWS CE and transfer them to an USB-stick.

Page 30

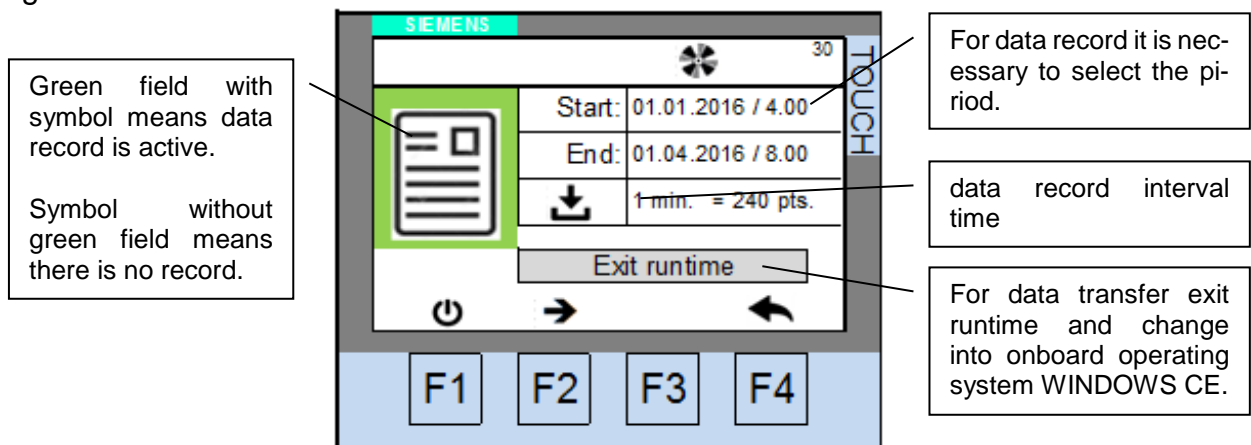

- F1 ON / OFF data record
- F2 next display
- F3 without function
- F4 Escape to normal display (page 02)

After you exit the runtime a new window will appear. Select "TASKBAR" and then open the WINDOWS-EXPLORER by double click on the symbol MY COMPUTER. Select the directory of the Storage-Card SD and then LOGS. Transfer the saved file KLIMASCHRANK0.csv from the Storage-Card SD with COPY+PASTE to the USB-stick as usual.

The file is formatted as a *.csv file. You can use EXCEL to import and analyse the data.

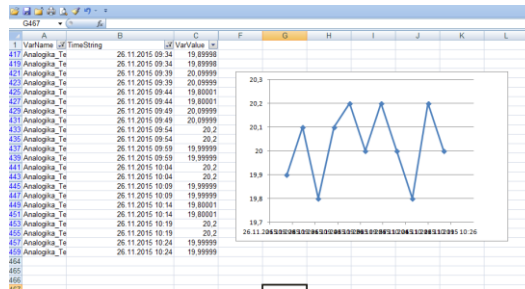

This page shows you a graphic report of the last 15 minutes. For more details use the buttons beneath the graphic.

<p>Note</p>	<p>After a voltage breakdown the recording must be restarted.</p>
-------------	---

4.6 Extras

Here it is possible to adjust a new date and time and select the language.

Page 40

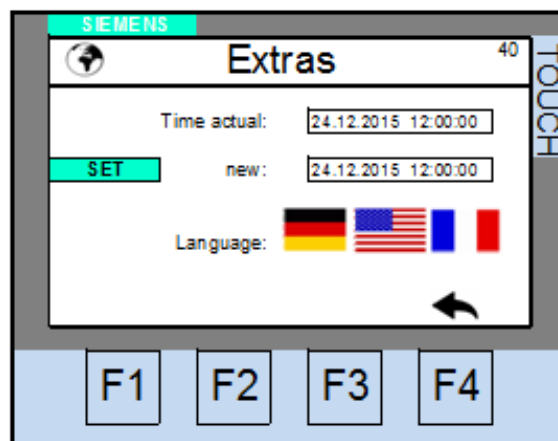

- F1 without function
- F2 without function
- F3 without function
- F4 Escape to normal display (page 01)

4.7 Messages and warnings on the display

Red field means:
Standby Modi in
Temperature and
Humidity
Press symbol to escape

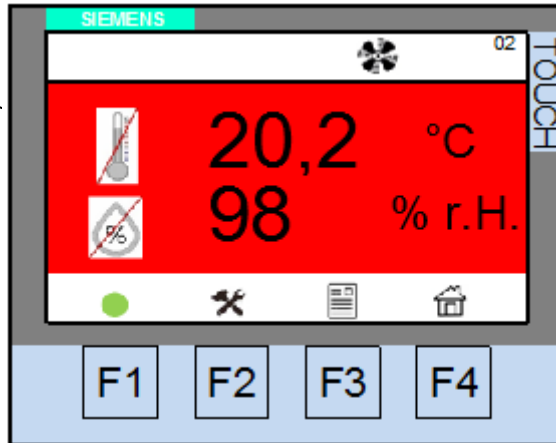

Yellow field means:
Limit range overflow
To adjust the range see display
page 11 and 13

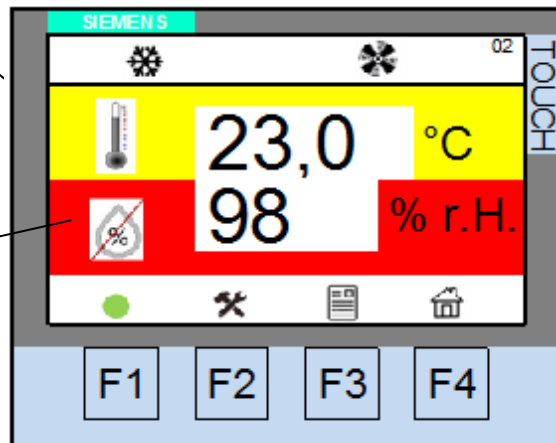

Red field means:
Standby Modi in
Humidity
Press symbol to escape

Yello field means:
One of the two installed fans
doesn't work
Regulation is still ON
Red field means:
Both fans do not work
Regulation is OFF
Find the cause; change the fan if
necessary by a skilled technician
After replacement confirm your
maintainance by touching the
field.

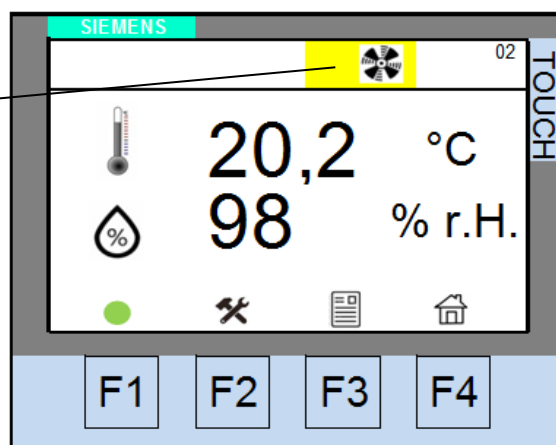

4.8 Calibration of the display value

After the Cabinet has been set up, it is necessary to use an officially calibrated reference testing system to measure the exact temperature and humidity that actually occurs inside the Cabinet. This is necessary to compare the actual temperature and the humidity of the interior of the Cabinet with the values being displayed by the system. If the values being displayed are not the same as the actual values inside the Cabinet as measured by the reference testing system, then proceed as follows:

Go to the display page 11 and display page 13 to make the correction.
Then change the value shown here so that it is the same as the value actually measured by the officially calibrated reference sensor.

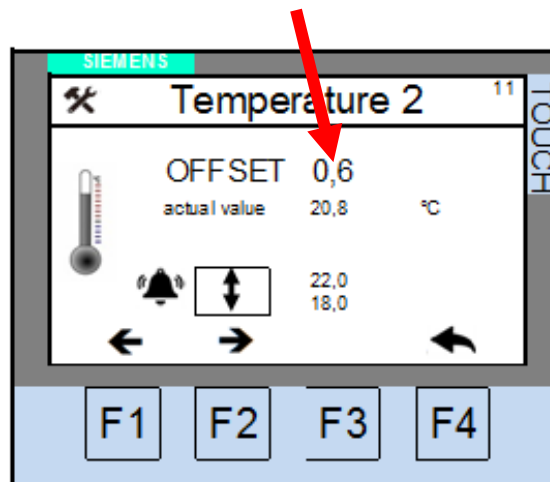

5. The humidification system

The enclosure of the humidification unit contains ultrasonic atomization modules, the solenoid valve, and the float switch.

A compact-designed atomization module is installed on the bottom of the water tank. It contains an oscillatory circuit, an amplifier, and an oscillator. The ultrasonic oscillations produced by this module are directed to the surface of the water in the tank. This effect reduces the water to fine particles (atomization).

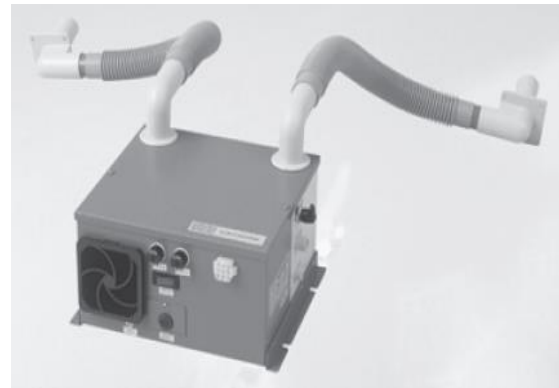

To achieve optimal atomization of the water, it is necessary to keep the water level in the tank as constant as possible. To provide these conditions, an automatic water-level control system with a solenoid valve and a float switch have been installed. When the water level in the tank falls below the normal level, the float switch goes ON, and the solenoid valve will open. This will allow water to flow into the tank. When the water in the tank has reached the proper level, the float switch will go OFF and will close the solenoid valve.

The Cabinet also contains an automatic feed-water monitoring system with a solenoid valve and a float switch, to protect the Cabinet from drying out.

If the water level in the tank falls below a pre-selected level, a float switch and a relay will automatically shut off the power to the Cabinet. A thermostat switches the power off when the temperature in the humidifier unit rises above a pre-selected point. Fuses and voltage-dependent resistors (varistors) are installed to protect the electronic system.

A fan blows the fog produced in the water tank through the fog emission pipes and into the Cabinet for Moist Storage of Mortar Prisms in Triple Moulds.

Range of permissible conditions and possible ambient conditions	
Water quality	< 5 $\mu\text{S}/\text{cm}$, briefly to 20 $\mu\text{S}/\text{cm}$
Power voltage for the humidifier unit	48 V AC + 10%
Permissible water pressure	0.5 ... 6 bar upstream (in front of) the humidifier
Temperature of input water to be used for the Cabinet	8 ... 30°C
Relative humidity (ambient)	< 90%
Air temperature (ambient)	5 ... 35°C

The User must provide a drain pipe connected to the building piping system to drain away the safety overflow from the humidifier, and to drain away the condensed water that collects in the system.

6. Maintenance, care, and cleaning of the system

6.1 General instructions

It may be necessary to conduct special maintenance work on the Cabinet for Moist Storage of Mortar Prisms in Triple Moulds: for example, repairs, exchange of parts, and any other work that is not described in this Operating Manual. If such work becomes necessary, then you must get into direct contact with the manufacturer.

After the Cabinet has been used for a longer period of time, we recommend that you give it a thorough cleaning on the outside and inside. The frequency and thoroughness of cleaning will depend on how often you use the Cabinet, and on the ambient conditions.

All maintenance work on the components of the Cabinet for Moist Storage of Mortar Prisms in Triple Moulds, and on its electrical system, must be conducted by specialists.

After a certain period of time, spots can form on the stainless-steel surfaces of the Cabinet, and the surfaces can become unsightly. In such cases, please use a normal, commercially available cleaning agent especially designed for stainless steel.

Every day, it is necessary to clean all parts and surfaces made of stainless steel with lukewarm soapy water. After cleaning, wipe off the cleaned parts with clear, warm water so that there is no soap remaining on the parts. Finally, carefully dry off all parts that you have cleaned.

<p>Caution</p> 	<p>Never use a direct stream of water or a high-pressure cleaning system to spray water onto the Cabinet for Moist Storage of Mortar Prisms in Triple Moulds. Such action would damage the system and would represent a safety hazard.</p>
	<p>Do NOT in any case use normal-steel wool or steel brushes or similar tools made of normal steel to clean the parts of the Cabinet. The use of such tools could cause particles containing iron to remain on the stainless steel surfaces of the Cabinet. This would cause rust spots by means of oxidation. If necessary in extreme cases, you may use stainless-steel wool to clean stubborn spots on the Cabinet. In this case, however, press the stainless-steel wool only in the direction of the satin finish of the Cabinet.</p>

The User is responsible to ensure that all maintenance, inspection, and assembly work is performed only by authorized and qualified specialist persons who have carefully studied all instructions in this Operating Manual.

If a water storage tank is used to provide the water for the Cabinet, it is necessary to check the level of the water in the tank **every day**.

From time to time, we recommend that you wipe dry the condensate catch pans at the bottom of the Cabinet, to remove any particles of building materials that may have fallen

to the bottom. To perform this cleaning, first remove the shelves and the bottom metal closure panel.

6.2 Care of the indicator instruments

To clean the plastic film on the front, use normally available cleaning agents: for example, household washing-up liquid. Do **NOT** use organic solvents such as petroleum ether, turpentine, kerosene, methylated alcohol, or the like. Also do not use high-pressure cleaning equipment.

6.3 Care of the humidifier

Never perform any maintenance or repair work on the Cabinet before shutting down the system. Before performing any repair or maintenance work, first switch off the power supply to the system. After shutting off the power, first use a meter to ensure that the system is in fact completely without electric power. **IMPORTANT:** It is in such cases absolutely necessary to follow the instructions given in this Operating Manual for shutting down the Cabinet. The User must provide a drain pipe connected to the building piping system to drain away the safety overflow from the humidifier, and to drain off the condensed water that collects in the system.

7. Troubleshooting

<p>Danger</p> 	<p>Any work done on the electrical components or systems must be performed by qualified specialist personnel.</p>
---	---

TROUBLE	CAUSE	SOLUTION
The interior of the Cabinet is too wet.	Controller setting is not correct.	Get in touch with the manufacturer.
	The sensor is defective.	Get in touch with the manufacturer.
	There is too much condensate, and too much water in the catch pan at the bottom.	Wipe out the condensate catch pan at the bottom. Make sure that the drain system is functioning properly.
	The drain of the condensate catch pan is stopped up.	Clean out the drain system and make sure it is working properly.
	The humidifier is producing too much moisture.	The controller settings are not correct. Get in touch with the manufacturer.
	The humidifying pipes are not in their correct positions.	Get in touch with the manufacturer.
The interior of the Cabinet is too dry.	There is no air circulation. The internal fans are defective.	Replace the circulation fans.
	The water supply is not functioning properly.	If using a water tank: refill with distilled water.
The interior of the Cabinet is too warm.	The humidifier is not switched on, or it switched itself off.	Check to make sure the water supply is properly functioning. Get in touch with the manufacturer.
	The cooling system is defective. The controller or the sensors are defective. The controller settings are not correct. The fans are defective. There is no proper air circulation.	Get in touch with the manufacturer.
The interior of the Cabinet is too cold.	The heating system is defective. The controller or the sensors are defective. The controller settings are not correct. The fans are defective. There is no proper air circulation.	Get in touch with the manufacturer.
The controllers do not show a measured value, although the main switch is ON.	Excessive voltage. Short circuit.	Take off the front panel of the Cabinet and turn ON the miniature circuit breakers in the electrical box. Find out why the circuit breakers tripped. Get in touch with the manufacturer.
	The miniature circuit breakers have been turned OFF.	
Pilot LED lamp illuminates	Not enough air circulation	Change fan

8. Placing the system out of operation

If the Cabinet should be placed out of operation for a lengthy period of time, it must be disconnected from the mains power supply. Then, during this time, conduct all maintenance on the system that is required. Drain or remove the water from all storage tanks. Cover the Cabinet to protect it from dust.

If the humidifier is not used over longer periods of time, the water must be drained as follows:

- Close the water-supply shut-off valve.
- Switch off the main power switch at the control box.

9. Scrapping the system

If the Cabinet cannot be further used, we recommend scrapping it as follows:

- Disconnect the equipment from the mains power
- Drain all the water out of the system
- Dispose of the refrigerant in accordance with currently valid laws.
- Take the system apart and scrap it in accordance with currently valid laws.

10. After-sales service

Great care was taken to assure that this Operating Manual was properly prepared. We cannot, however, guarantee that it has no mistakes, or that all data are complete and correct in the event of technical modifications.

10.1 Date of this version of the Operating Manual

Version no. 12th
Aug 2019

10.2 Copyright

The copyright to this Operating Manual is held by:

TESTING Bluhm & Feuerherdt GmbH

This Operating Manual is intended for use only by the User and his/her staff. It contains instructions and data that may NOT be:

- Reproduced,
- Distributed, or
- Provided to any third party.

Any person acting in violation of the above stipulations may be prosecuted before a court of law.

10.3 Spare parts and technical help

If you have any questions of technical nature, or if you need spare parts, please get in touch with the following address:

TESTING Bluhm & Feuerherdt GmbH
Motzener Str. 26b
DE – 12277 Berlin
Germany

Tel. [+ 49 30] 710 96 45-0
Fax [+ 49 30] 710 96 45 98
www.testing.de
info@testing.de

Cabinet for Moist Storage
of Mortar Prisms in Triple Moulds
1.0321.03 / 1.0321.04 / 1.0321.05

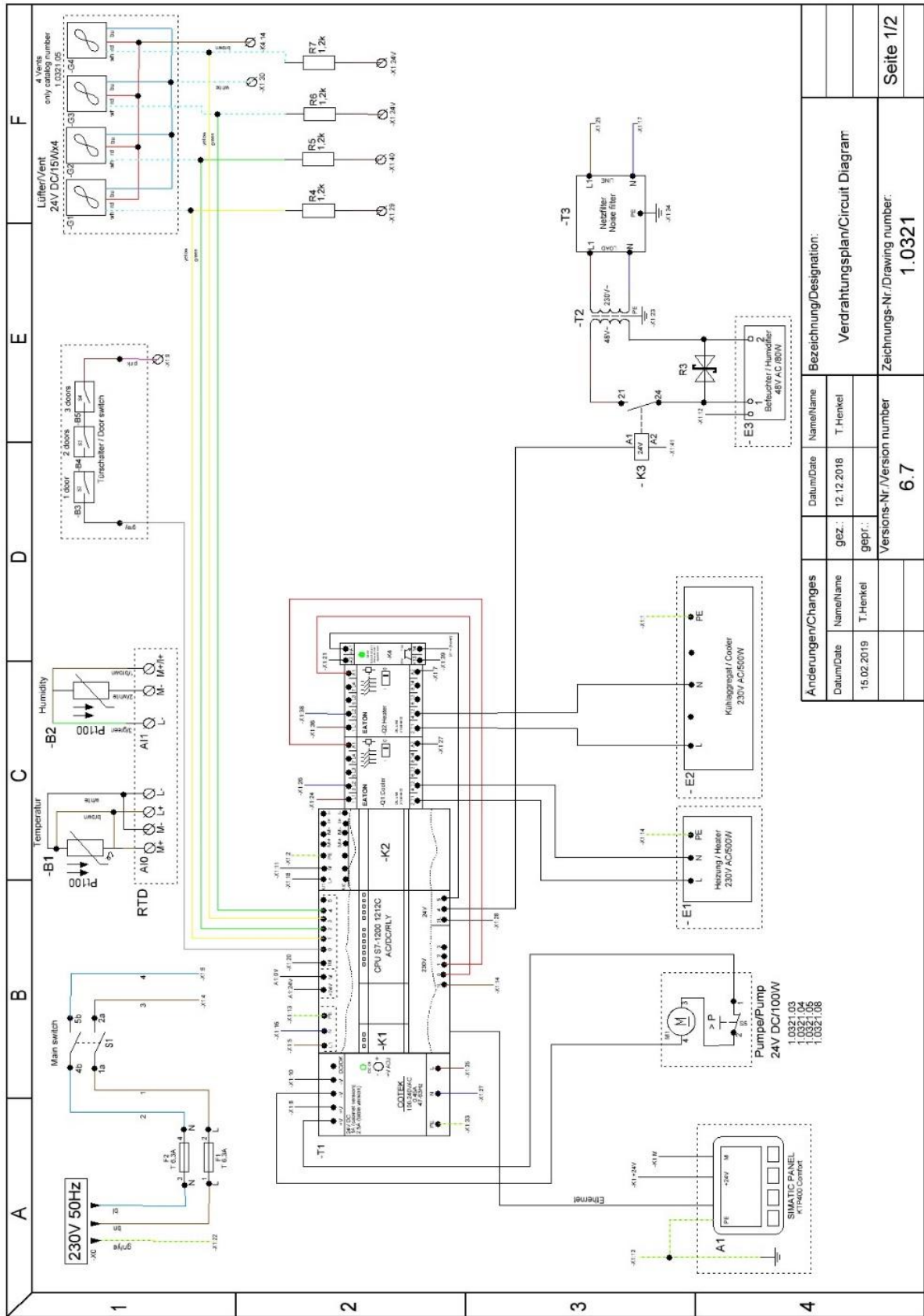

Anderungen/Changes		Bezeichnung/Designation:	
Datum/Date	Name/Name	Verdrahtungsplan/Circuit Diagram	
15.02.2019	T.Henkel		
gepr.:	gepr.:		
Versions-Nr./Version number		Zeichnungs-Nr./Drawing number:	
6.7		1.0321	
		Seite 1/2	

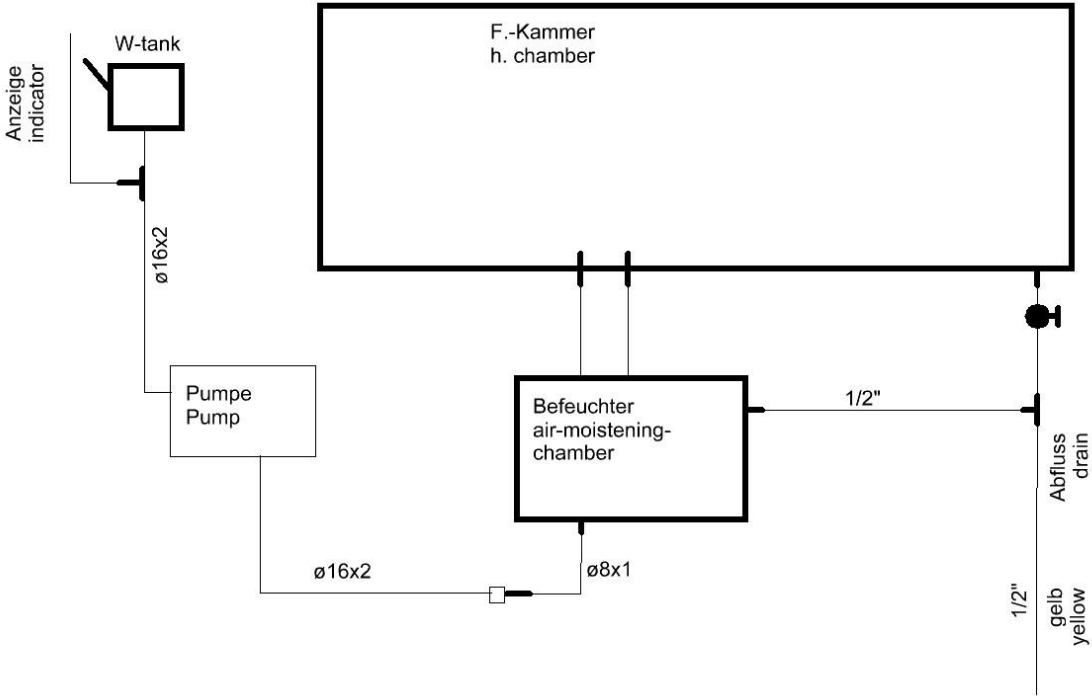

**EC Declaration of Conformity in accordance with the Machinery Directive
2006/42/EC Appendix II 1.A**

The authorised representative established in the community,

Mr. Feuerherdt

hereby declares that the following product

Manufacturer: TESTING Bluhm & Feuerherdt GmbH
Motzener Str. 26b
12277 Berlin
Product designation: 1.0321.03 / 1.0321.04 / 1.0321.05
Serial/Type designation: Cabinet for Moist Storage

complies with all of the relevant provisions of the above named guidelines as well as the additional applied guidelines (following) - including any of the amendments thereto which are in force at the time of the declaration.

The following additional EU Directives have been applied:

Low Voltage Directive 2014/35/EC

The following harmonised standards have been applied:

DIN EN 60204-1 The Safety of Machines - Electrical Equipment of Machines - Part 1: General Requirements (corrigendum 2010)
DIN EN ISO 12100 Safety of machinery - General principles for design - Risk assessment and risk reduction (corrigendum 2013)

The name and address of the person who has been authorised to compile the technical documentation:

Mr. Metge

Location: Berlin

Date: 28/02/2014



(Signature)
Managing Director



(Signature)
Technician